

X20AO2622

1 General information

The module is equipped with 2 outputs with 13-bit (including sign) digital converter resolution. It is possible to select between the current and voltage signal using different terminals.

This module is designed for X20 6-pin terminal blocks. If needed (e.g. for logistical reasons), the 12-pin terminal block can also be used.

- 2 analog outputs
- Either current or voltage signal possible
- 13-bit digital converter resolution

2 Order data

Model number	Short description	Figure
	Analog outputs	
X20AO2622	X20 analog output module, 2 outputs, 10 V or 0 to 20 mA / 4 to 20 mA, 13-bit converter resolution	
	Required accessories	
	Bus modules	
X20BM11	X20 bus module, 24 VDC keyed, internal I/O supply continuous	
X20BM15	X20 bus module, with node number switch, 24 VDC keyed, internal I/O supply continuous	
	Terminal blocks	
X20TB06	X20 terminal block, 6-pin, 24 VDC keyed	
X20TB12	X20 terminal block, 12-pin, 24 VDC keyed	

Table 1: X20AO2622 - Order data

3 Technical data

Model number	X20AO2622
Short description	
I/O module	2 analog outputs ± 10 V or 0 to 20 mA / 4 to 20 mA ¹⁾
General information	
B&R ID code	0x1BA2
Status indicators	I/O function per channel, operating state, module status
Diagnostics	
Module run/error	Yes, using LED status indicator and software
Channel type	Yes, using software
Power consumption	
Bus	0.01 W
Internal I/O	1.1 W
Additional power dissipation caused by actuators (resistive) [W]	-
Certifications	
CE	Yes
ATEX	Zone 2, II 3G Ex nA nC IIA T5 Gc IP20, Ta (see X20 user's manual) FTZÚ 09 ATEX 0083X
UL	cULus E115267 Industrial control equipment
HazLoc	cCSAus 244665 Process control equipment for hazardous locations Class I, Division 2, Groups ABCD, T5
DNV GL	Temperature: B (0 - 55°C) Humidity: B (up to 100%) Vibration: B (4 g) EMC: B (bridge and open deck)
LR	ENV1
KR	Yes
EAC	Yes
KC	Yes
Analog outputs	
Output	± 10 V or 0 to 20 mA / 4 to 20 mA, via different terminal connections ¹⁾
Max. output current	10 mA at voltage >5 V 15 mA at voltage <5 V
Digital converter resolution	
Voltage	± 12 -bit
Current	12-bit
Conversion time	200 μ s for all outputs
Settling time on output change over entire range	1 ms
Switch on/off behavior	Internal enable relay for startup
Max. error	
Voltage	
Gain	0.15% ²⁾
Offset	0.05% ³⁾
Current	
Gain	0.15% ²⁾
Offset	0.05% ³⁾
Output protection	Short-circuit proof
Output format	
Voltage	INT 0x8001 - 0x7FFF / 1 LSB = 0x0008 = 2.441 mV
Current	INT 0x0000 - 0x7FFF / 1 LSB = 0x0008 = 4.883 μ A
Load per channel	
Voltage	Max. ± 10 mA, load ≥ 1 k Ω
Current	Load max. 600 Ω (Rev. \geq J0), 500 Ω (Rev. < J0)
Short-circuit proof	Current limiting ± 40 mA
Output filter	First-order low-pass filter / cutoff frequency 10 kHz
Max. gain drift	
Voltage	0.02%/°C ²⁾
Current	0.02%/°C ²⁾
Max. offset drift	
Voltage	0.032%/°C ³⁾
Current	0.032%/°C ³⁾
Error caused by load change	
Voltage	Max. 0.11%, from 10 M Ω \rightarrow 1 k Ω , resistive
Current	Max. 0.5%, from 1 Ω \rightarrow 600 Ω , resistive
Nonlinearity	<0.007% ⁴⁾
Isolation voltage between channel and bus	500 V _{eff}
Electrical properties	
Electrical isolation	Channel isolated from bus Channel not isolated from channel

Table 2: X20AO2622 - Technical data

Model number	X20AO2622
Operating conditions	
Mounting orientation	
Horizontal	Yes
Vertical	Yes
Installation elevation above sea level	
0 to 2000 m	No limitation
>2000 m	Reduction of ambient temperature by 0.5°C per 100 m
Degree of protection per EN 60529	IP20
Ambient conditions	
Temperature	
Operation	
Horizontal mounting orientation	-25 to 60°C
Vertical mounting orientation	-25 to 50°C
Derating	-
Storage	-40 to 85°C
Transport	-40 to 85°C
Relative humidity	
Operation	5 to 95%, non-condensing
Storage	5 to 95%, non-condensing
Transport	5 to 95%, non-condensing
Mechanical properties	
Note	Order 1x terminal block X20TB06 or X20TB12 separately Order 1x bus module X20BM11 separately.
Pitch	12.5 ^{+0.2} mm

Table 2: X20AO2622 - Technical data

- 1) 4 to 20 mA: Starting with upgrade version 1.0.2.0 or hardware revision "I0"
- 2) Based on the current output value.
- 3) Based on the entire output range.
- 4) Based on the output range.

4 LED status indicators

For a description of the various operating modes, see section "Additional information - Diagnostic LEDs" of the X20 system user's manual.

Figure	LED	Color	Status	Description
	r	Green	Off	No power to module
			Single flash	RESET mode
			Double flash	BOOT mode (during firmware update) ¹⁾
			Blinking	PREOPERATIONAL mode
			On	RUN mode
	e	Red	Off	No power to module or everything OK
			On	Error or reset status
	e + r	Red on / Green single flash	Invalid firmware	
	1 - 2	Orange	Off	Value = 0
			On	Value ≠ 0

- 1) Depending on the configuration, a firmware update can take up to several minutes.

5 Pinout

The individual channels can be configured for either current or voltage signals. The type of signal is also determined by the terminals used.

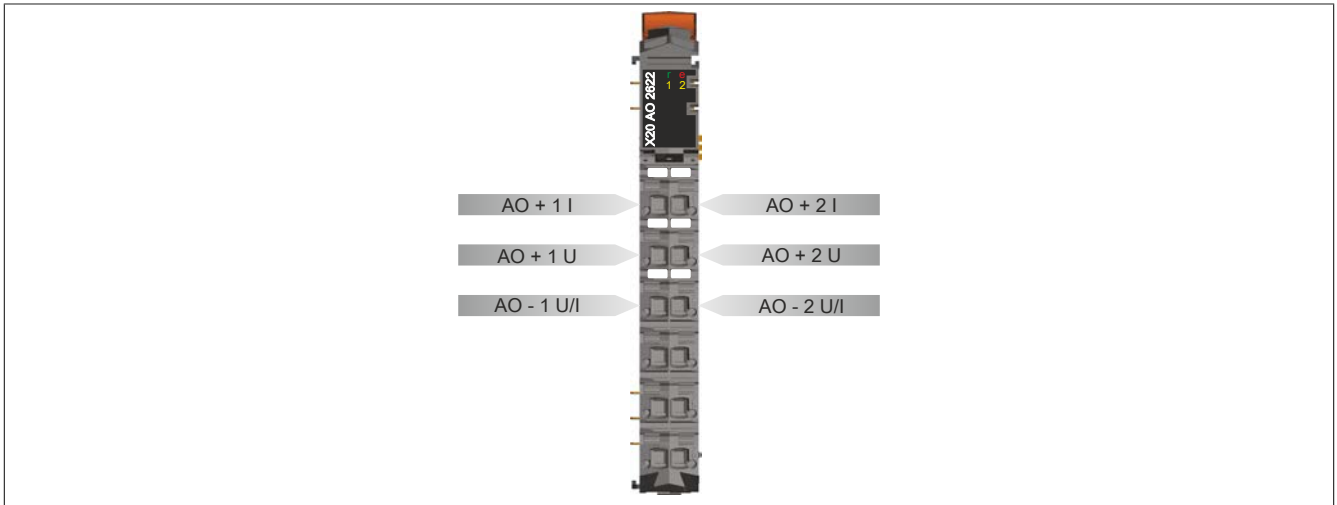

6 Connection example

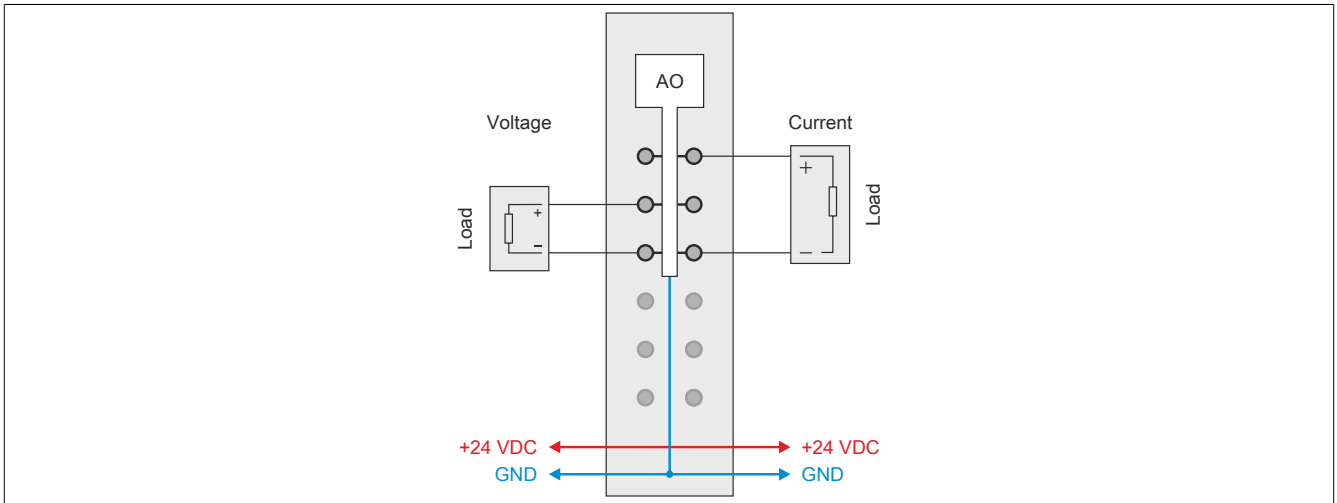

7 Output circuit diagram

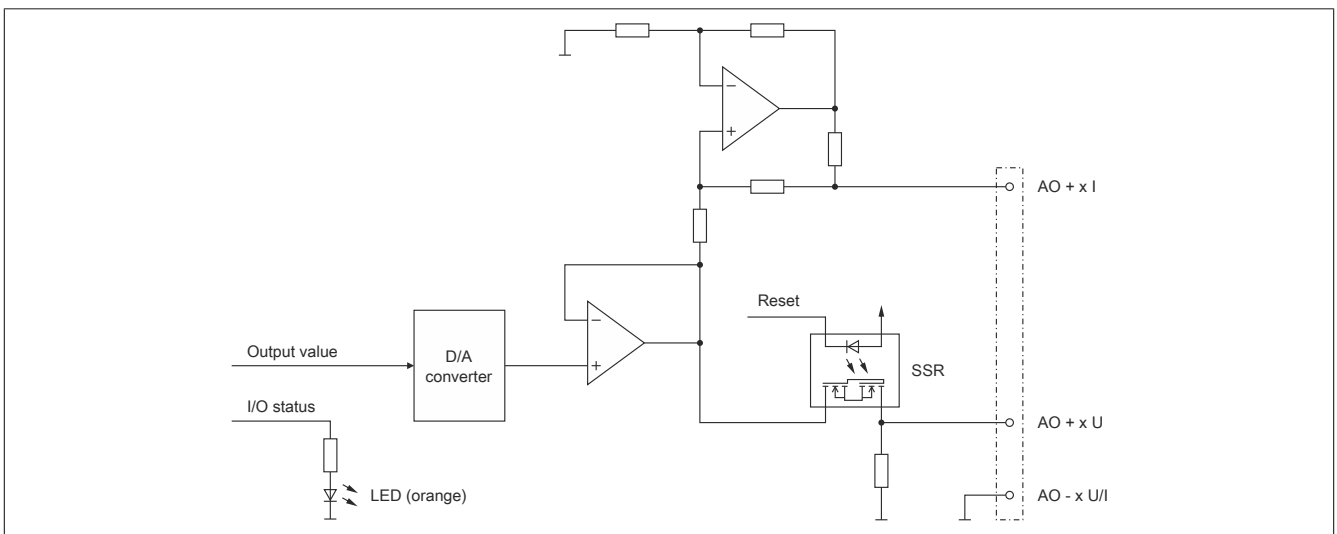

8 Register description

8.1 General data points

In addition to the registers described in the register description, the module has additional general data points. These are not module-specific but contain general information such as serial number and hardware variant.

General data points are described in section "Additional information - General data points" of the X20 system user's manual.

8.2 Function model 0 - Standard and function model 1 - I/O with fast reaction

Register	Name	Data type	Read		Write	
			Cyclic	Non-cyclic	Cyclic	Non-cyclic
Configuration						
18	ConfigOutput01	USINT				•
Communication						
0	AnalogOutput01	INT			•	
2	AnalogOutput02	INT			•	

8.3 Function model 254 - Bus controller

Register	Offset ¹⁾	Name	Data type	Read		Write	
				Cyclic	Non-cyclic	Cyclic	Non-cyclic
Configuration							
18	-	ConfigOutput01 (channel type)	USINT				•
Communication							
0	0	AnalogOutput01	INT			•	
2	2	AnalogOutput02	INT			•	

1) The offset specifies the position of the register within the CAN object.

8.3.1 Using the module on the bus controller

Function model 254 "Bus controller" is used by default only by non-configurable bus controllers. All other bus controllers can use other registers and functions depending on the fieldbus used.

For detailed information, see section "Additional information - Using I/O modules on the bus controller" of the X20 user's manual (version 3.50 or later).

8.3.2 CAN I/O bus controller

The module occupies 1 analog logical slot on CAN I/O.

8.4 Function model comparison

Function model 0: I/O without jitter (standard)

Corrected values are output in the next cycle if the minimum cycle is $\geq 300 \mu\text{s}$ in order to reduce jitter to a minimum.

Function model 1: I/O with fast reaction

Corrected values are output in the same cycle if the minimum cycle is $\geq 300 \mu\text{s}$ (optimized reactions).

Comparison of the two function models

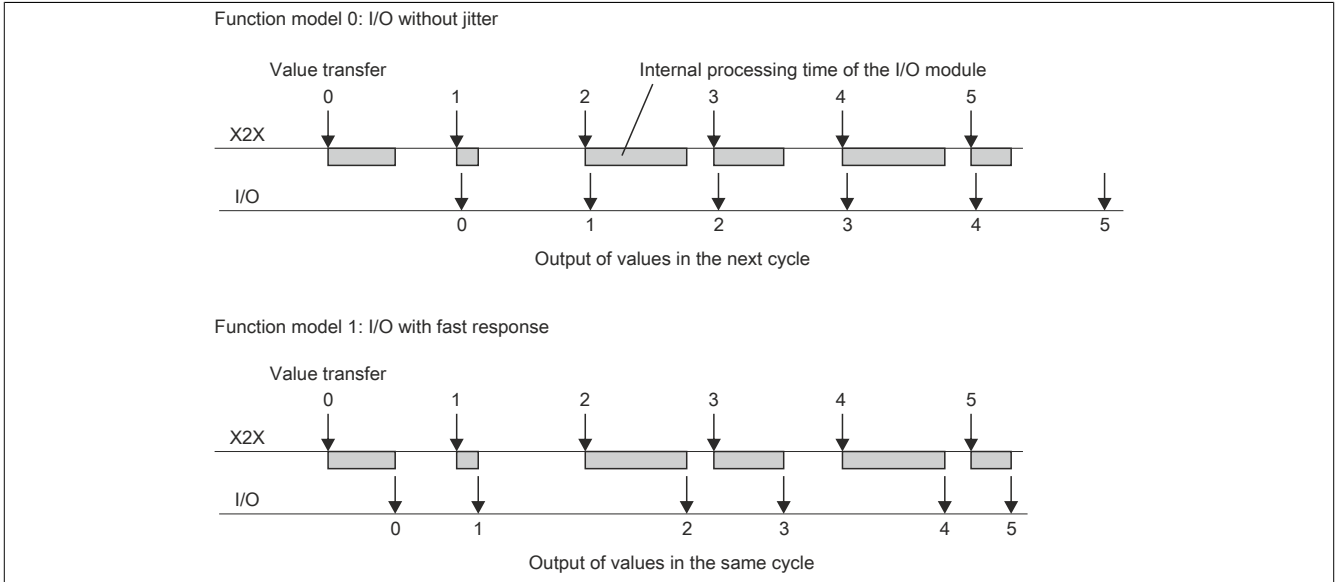

8.5 Analog outputs

The individual channels can be configured for either current or voltage signals. The type of signal is also determined by the terminals used.

8.5.1 Output values of the analog outputs

Name:

AnalogOutput01 to AnalogOutput02

These registers provide the standardized output values. Once a permitted value is received the module outputs the respective current or voltage.

Data type	Value	Information
INT	-32768 to 32767	Voltage signal -10 to 10 VDC
	0 to 32767	Current signal 0 to 20 mA
	0 to 32767	Current signal 4 to 20 mA ¹⁾

1) From upgrade version 1.0.2.0 or hardware revision "I0"

8.5.2 Setting the channel type

Name:

ConfigOutput01

This register can be used to set the channel type of the outputs.

Each channel is capable of handling either current or voltage signals. The type of signal is determined by the terminal connections used. Since current and voltage require different adjustment values, it is also necessary to configure the desired type of output signal. The following output signals can be set:

- ± 10 V voltage signal (default)
- 0 to 20 mA current signal
- 4 to 20 mA current signal

Data type	Values	Bus controller default setting
USINT	See the bit structure.	0

Bit structure:

Bit	Name	Value	Information
0	Channel 1	0	Voltage signal (bus controller default setting)
		1	Current signal, measurement range corresponding to bit 4
1	Channel 2	0	Voltage signal
		1	Current signal, measurement range corresponding to bit 5
2 - 3	Reserved	0	
4	Channel 1: Current measurement range	0	0 to 20 mA current signal
		1	4 to 20 mA current signal
5	Channel 2: Current measurement range	0	0 to 20 mA current signal
		1	4 to 20 mA current signal
6 - 7	Reserved	0	

8.6 Minimum cycle time

The minimum cycle time specifies the time up to which the bus cycle can be reduced without communication errors occurring. It is important to note that very fast cycles reduce the idle time available for handling monitoring, diagnostics and acyclic commands.

Minimum cycle time
250 μ s

8.7 Minimum I/O update time

The minimum I/O update time specifies how far the bus cycle can be reduced so that an I/O update is performed in each cycle.

Minimum I/O update time
300 μ s