

8AC110.60-2

1 General information

The AC110 plug-in module can be used in an ACOPOS slot. The module is equipped with a CAN interface. This fieldbus interface is used for communication and setting parameters on the ACOPOS servo drive for standard applications.

2 Order data

Model number	Short description	Figure
	Plug-in modules	
8AC110.60-2	ACOPOS plug-in module, CAN interface	
	Optional accessories	
	Infrastructure components	
0AC912.9	Bus adapter, CAN, 1 CAN interface	
0AC913.92	Bus adapter, CAN, 2 CAN interfaces, including 30 cm attachment cable (DSUB)	
7AC911.9	Bus connector, CAN	

Table 1: 8AC110.60-2 - Order data

3 Technical data

Product ID	8AC110.60-2
General information	
Module type	ACOPOS plug-in module
B&R ID code	0x1198
Slot	Slot 1
Power consumption	Max. 0.7 W
Certification	
CE	Yes
cULus	Yes
KC	Yes
Interfaces	
CAN	
Quantity	1
Module-side connection	9-pin male DSUB connector
Status indicators	RXD/TXD LEDs
Baud rate	500 kbit/s
Bus terminating resistor	Externally wired
Electrical isolation	Yes
Max. distance	60 m
Network-capable	Yes
Environmental conditions	
Temperature	
Operation	
Nominal	5 to 40°C
Maximum	55°C
Storage	-25 to 55°C
Transport	-25 to 70°C
Relative humidity	
Operation	5 to 85%
Storage	5 to 95%
Transport	Max. 95% at 40°C

Table 2: 8AC110.60-2 - Technical data

4 CAN node number settings

The CAN node number can be set using two HEX switches:

Figure	Rotary code switch	CAN node number
	①	16s position (high)
	②	1s position (low)
<p>The node number change takes effect the next time the ACOPOS servo drive is switched on.</p> <p>Information:</p> <p>Changing the node number using software is not possible (Basis CAN ID can be changed). The ACOPOS Manager only supports node numbers 1 - 32.</p>		

Table 3: Setting the CAN node number

There must be a terminating resistor (120 Ω , 0.25 W) between CAN_H and CAN_L at the beginning and end of the CAN bus.

5 Status indicators

The status LEDs indicate if data is being received (RXD) or sent (TXD).

6 Firmware

The firmware is part of the operating system for the ACOPOS servo drives. Firmware is updated by updating the ACOPOS operating system.

7 Wiring

7.1 Pinout

Figure	X11	Pin	Name	Function
		1	---	---
		2	CAN_L	CAN low
		3	COM (2, 7))	0 V CAN card
		4	---	---
		5	---	---
		6	---	---
		7	CAN_H	CAN high
		8	---	---
		9	---	---

Table 4: AC110 CAN interface - Pinout

7.2 Input/Output circuit diagram

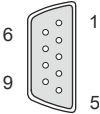
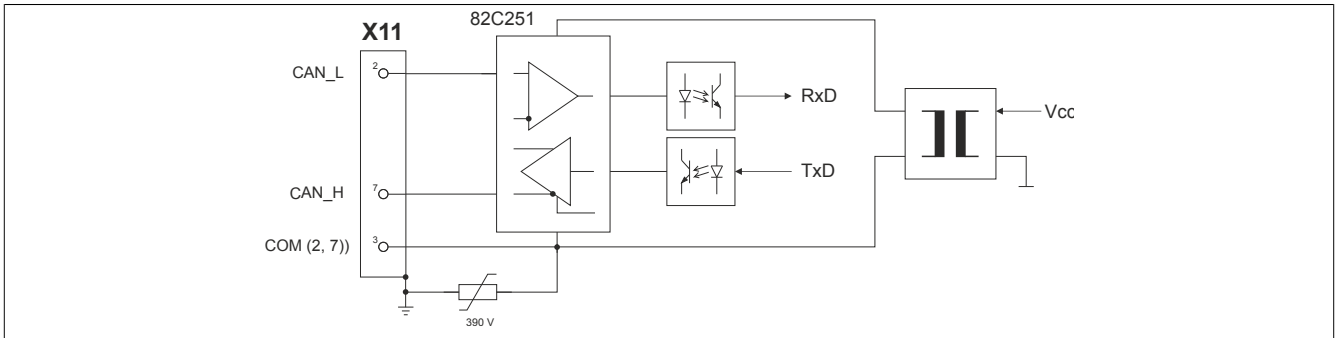

Figure 1: AC110 - Input/Output circuit diagram