

## M18 Cylindrical Photoelectric

## E3F2

### Threaded Cylindrical M18 Size Sensors with Built-in Amplifier

- Rugged stainless and nickel plated brass versions
- Chemical resistant, ABS resin case type
- Polarized models
- Compact and space-saving
- Long detection distance (7 m)
- DC switching types with connectors for easy maintenance
- Wide operating voltage range (10 to 30 VDC, or 24 to 240 VAC)
- Short-circuit and reverse connection protection (DC switching type)
- UL, CSA listed and CE marked



## Ordering Information

### ■ SENSORS

Supply	Type	Connection	Output	Range	Housing	Part number
AC	Through-beam	Pre-leaded	Light-On	3 m	Plastic	<b>E3F2-3Z1</b>
			Dark-On		Plastic	<b>E3F2-3Z2</b>
	Retroreflective, Non-polarized		Light-On	2 m	Plastic	<b>E3F2-R2Z1</b>
			Dark-On		Plastic	<b>E3F2-R2Z2</b>
	Diffuse		Light-On	100 mm	Plastic	<b>E3F2-DS10Z1N</b>
			Dark-On		Plastic	<b>E3F2-DS10Z2N</b>
DC	Through-beam	Connector	NPN	7 m	Plastic	<b>E3F2-7C4-P1</b>
					NPB	<b>E3F2-7C4-M1-C</b>
					SS	<b>E3F2-7C4-M1-S</b>
			PNP		Plastic	<b>E3F2-7B4-P1</b>
					NPB	<b>E3F2-7B4-M1-C</b>
					SS	<b>E3F2-7B4-M1-S</b>
	Diffuse		NPN	10 cm	NPB	<b>E3F2-DS10C4-M1-C</b>
					SS	<b>E3F2-DS10C4-M1-S</b>
			Plastic		<b>E3F2-DS10C4-P1</b>	
					Plastic	<b>E3F2-DS30C4-P1</b>
		30 cm				

Note: NPB = Nickel plated brass; SS = Stainless steel

(This table continues on the next page.)

Ordering Information Table - continued from previous page

Supply	Type	Connection	Output	Range	Housing	Part number		
DC	Diffuse	Connector	PNP	10 cm	NPB	E3F2-DS10B4-M1-C		
					SS	E3F2-DS10B4-M1-S		
					Plastic	E3F2-DS10B4-P1		
				30 cm	Plastic	E3F2-DS30B4-P1		
	Retroreflective, Non-polarized		NPN	Pre-leaded	2 m	Plastic	E3F2-R2C4-P1	
						Plastic	E3F2-R2B4-P1	
						NPB	E3F2-R2RC4-M1-C	
						SS	E3F2-R2RC4-M1-S	
		PNP	NPB		E3F2-R2RB4-M1-C			
			SS		E3F2-R2RB4-M1-S			
			Through-beam		NPN	7 m	Plastic	E3F2-7C4
							NPB	E3F2-7C4-C
	SS	E3F2-7C4-S						
	PNP	7 m		Plastic	E3F2-7B4			
			NPB	E3F2-7B4-C				
			SS	E3F2-7B4-S				
	Diffuse	NPN	10 cm	NPB	E3F2-DS10C4-C			
				Plastic	E3F2-DS10C4-N			
				SS	E3F2-DS10C4-S			
				30 cm	Plastic	E3F2-DS30C4		
		PNP	10 cm	NPB	E3F2-DS10B4-C			
				Plastic	E3F2-DS10B4-N			
				SS	E3F2-DS10B4-S			
				30 cm	Plastic	E3F2-DS30B4		
Retroreflective, Non-polarized	NPN	2 m	Plastic	E3F2-R2C4				
			Plastic	E3F2-R2B4				
	PNP		NPB	E3F2-R2RC4-C				
			SS	E3F2-R2RC4-S				
Retroreflective, Polarized	NPN	2 m	NPB	E3F2-R2RB4-C				
			SS	E3F2-R2RB4-S				
	PNP		NPB	E3F2-R2RC4-C				
			SS	E3F2-R2RB4-S				

Note: NPB = Nickel plated brass; SS = Stainless steel

## ■ ACCESSORIES (ORDER SEPARATELY)

Description	Part number
Sensor mounting bracket	Y92E-B18
Lens protector kit (glass plate, two gaskets and metal retainer)	E39-F31
Small corner cube reflector (38 H x 20 W x 11 D mm)	E39-R3
Adhesive backed reflector tape (10 H x 35 W x 0.7 D mm)	E39-RSA
Adhesive backed reflector tape (35 H x 40 W x 0.7 D mm)	E39-RSB
Mounting bracket for E39-R1 reflector	E39-L7
Right angle adapter for through-beam and retroreflective E3F2 sensors	E39-RU1

## ■ CONNECTOR CORDSETS

Connector type	Cable size	Length	Straight connector	Right angle connector
4-wire DC Micro Change® connector	22 AWG	2 m (6.56 ft)	Y96E-44SD2	Y96E-44RD2
		5 m (16.40 ft)	Y96E-44SD5	Y96E-44RD5
		10 m (32.8 ft)	Y96E-44SD10	Y96E-44RD10
Robotic cable with M12 connector		2 m (6.56 ft)	XS2F-D421-D80-R	XS2F-D422-D80-R
		5 m (16.40 ft)	XS2F-D421-G80-R	XS2F-D422-G80-R

## ■ REPLACEMENT PARTS

Description	Part number
Reflector for E3F2-R2□4 retroreflective sensors	E39-R1
Two plastic M18 mounting nuts	M18-PHWS

## Specifications

### ■ DC SWITCHING MODELS

Part number	E3F2-7C4-□, E3F2-7B4-□	E3F2-R2C4-□, E3F2-R2B4-□	E3F2-R2RC4-□, E3F2-R2RB4-□	E3F2-DS10C4-□, E3F2-DS10B4-□	E3F2-DS30C4-□, E3F2-DS30B4-□
Method of detection	Through-beam	Retroreflective Non-polarized      Polarized		Diffuse	
Sensing range	7 m (22.96 ft)	2 m (6.56 ft)	2 m (6.56 ft)	10 cm (3.94 in)	30 cm (11.81 in)
Standard target	11 x 11 mm	56 x 56 mm		5 x 5 cm 90% Kodak White Card	10 x 10 cm 90% Kodak White Card
Supply voltage	10-30 VDC 10% maximum permissible ripple, peak-to-peak				
Output	NPN or PNP open collector, 100 mA, residual voltage 2 V max. at 100 mA				
Current consumption	45 mA max.	25 mA max.			
Response time	2.5 ms max.				
Stabilization on Powerup	50 ms				
Ambient temperature	Operating	-25°C to 55°C (-13°F to 131°F) with no icing			
	Storage	-30°C to 70°C (-22°F to 158°F)			
Ambient light immunity	Incandescent: 3,000 lx; Sunlight: 10,000 lx				
Relative humidity	Operating	35% to 85% RH, no condensation			
	Storage	35% to 95% RH			
Insulation resistance	20 MΩ at 500 VDC				
Dielectric strength	1,000 VAC, 50/60 Hz for 1 min. between current carrying parts and case				
Vibration	10 to 55 Hz 1.5 mm double amplitude 1 hr each in X, Y, Z axes				
Shock	500 m/s <sup>2</sup> (approx. 50 G)				
Enclosure	IP67, NEMA 6 for metal versions; IP66 NEMA, 4 for plastic versions				
Light source	Infrared LED		Red LED	Infrared LED	
Indicators	Power and light received LEDs				
Sensitivity adjustment	Fixed				Adjustable
Operation mode	Light-ON or Dark-ON selectable with control wire				
Weight	Metal	Pre-leaded 100 g; connector: 60 g			
	Plastic	Pre-leaded 85 g; connector: 40 g			
Circuit protection	Output short-circuit and reverse polarity				
Materials	Lens	Plastic			
	Housing	Plastic (ABS), nickel plated brass, stainless steel	Plastic	Nickel plated brass, stainless steel	Plastic (ABS), nickel plated brass, stainless steel
	Cable sheath	PVC			

## ■ AC MODELS

Part number	E3F2-3Z1, E3F2-3Z2	E3F2-R2Z1, E3F2-R2Z2	E3F2-DS10Z1N, E3F2-DS10Z2N
Method of detection	Through-beam	Retroreflective	Diffuse
Sensing range	3 m (9.84 ft)	2 m (6.56 ft)	10 cm (3.94 in)
Standard target	11 mm	56 mm	10 x 10 cm 90% Kodak white card
Supply voltage	24-240 VAC $\pm$ 10%, 50/60 Hz		
Output	SCR 200 mA max.; residual voltage 5 V max. at 200 mA		
Power consumption	10 mA max.	5 mA max.	
Response time	30 ms max.		
Stabilization on Powerup	100 ms		
Ambient temperature	Operating	-25°C to 55°C (-13°F to 131°F) with no icing	
	Storage	-30°C to 70°C (-22°F to 158°F)	
Ambient light immunity	Incandescent: 3,000 lx; sunlight: 10,000 lx		
Relative humidity	Operating	35% to 85% RH, no condensation	
	Storage	35% to 95% RH	
Insulation resistance	20 M $\Omega$ at 500 VDC between current carrying parts and case		
Dielectric strength	1,500 VAC, 50/60 Hz for 1 min. between current carrying parts and case		
Vibration	10 to 55 Hz 1.5 mm double amplitude 2 hrs each in X, Y, Z axes		
Shock	500 m/s <sup>2</sup> (approx. 50 G)		
Enclosure	IP66, NEMA 1, 2, 4 (indoor)		
Light source	Infrared LED		
Indicators	Power and light received LEDs		
Sensitivity adjustment	Fixed		
Operation mode	Light-ON (Z1 models) or Dark-ON (Z2 models)		
Weight	Pre-leaded models	110 g	
	Connector models	55 g	
Circuit protection	—		
Materials	Lens	Acrylate resin	
	Housing	Plastic ABS	
	Cable sheath	PVC	

# Engineering Data

## OPERATING RANGE (TYPICAL)

E3F2-3□□-□□ (Through-beam)

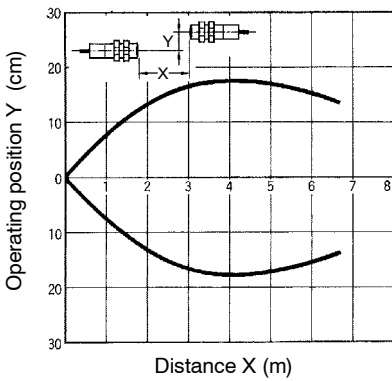

E3F2-R2□□-□□ (Retroreflective)

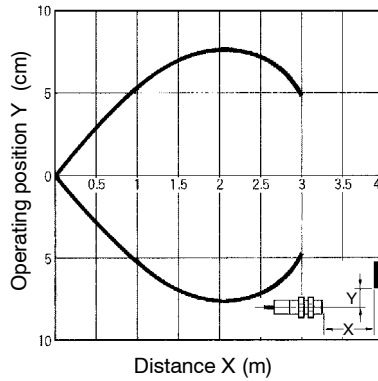

E3F2-3 and E39-RU1 (Right angle adapter)

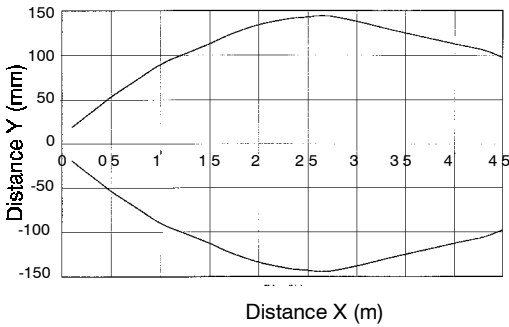

E3F2-R2 and E39-RU1 (Right angle adapter)

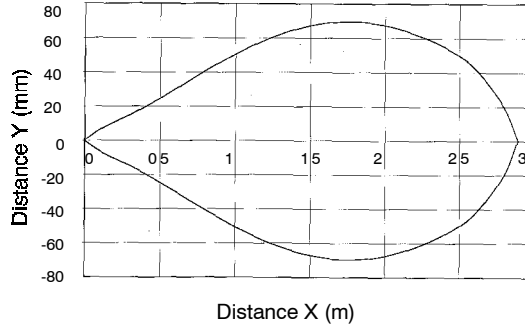

E3F2-7□□-4□ (Through-beam)

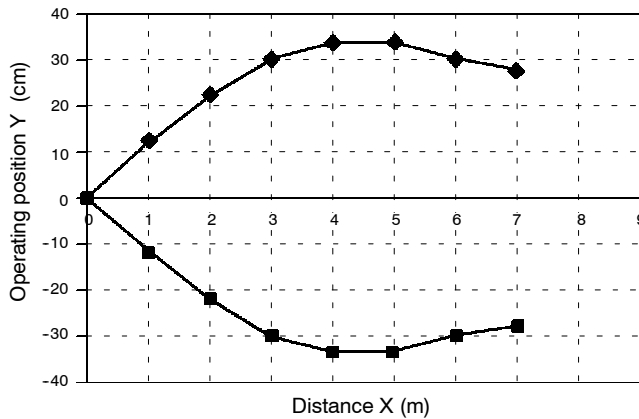

E3F2-R2R□□-4□ (Polarized, retroreflective)

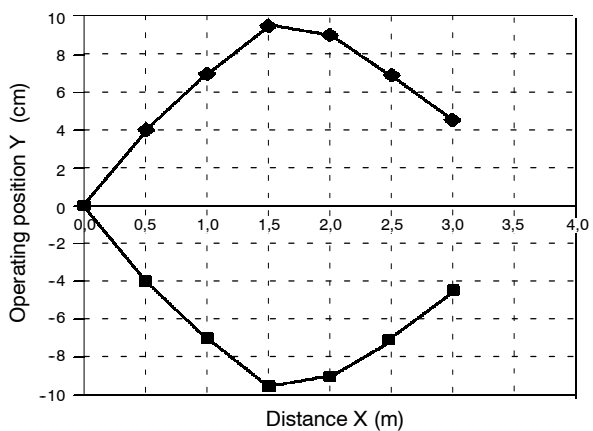

E3F2-DS10□□4-N  
E3F2-DS10□□4-P1

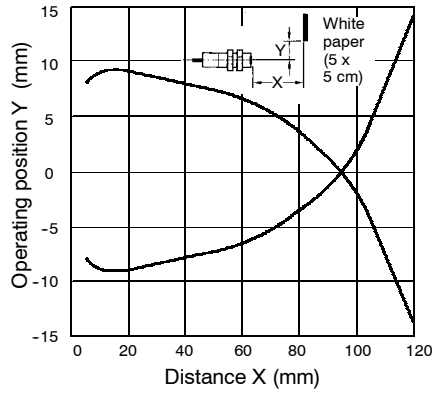

E3F2-DS30□□-□□ (Diffuse)

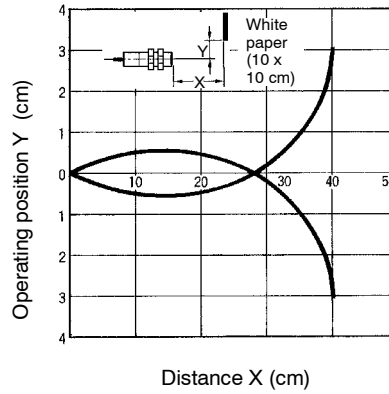

■ EXCESS GAIN VS. SET DISTANCE (TYPICAL)

E3F2-3□□-□□ (Through-beam)

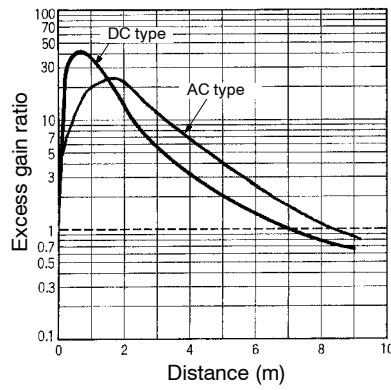

E3F2-R2□□-□□ (Retroflective, Non-polarized)

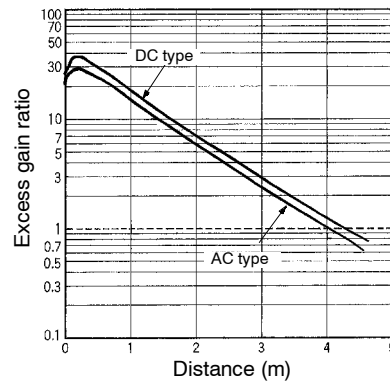

E3F2-3 and E39-RU1 (Right angle adapter)

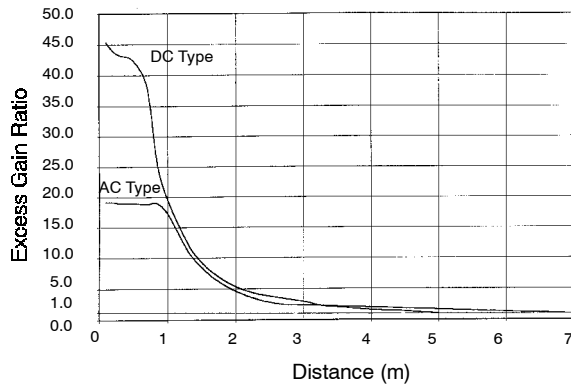

E3F2-R2 and E39-RU1 (Right angle adapter)

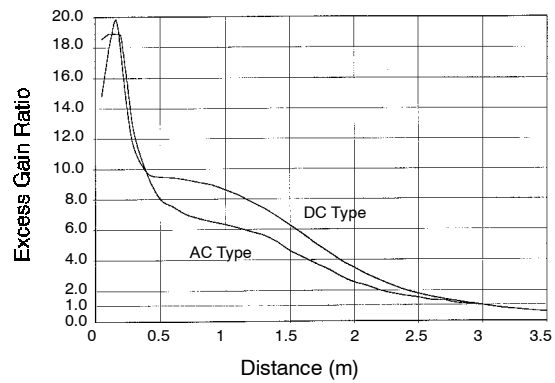

E3F2-7□4□ (Through beam)

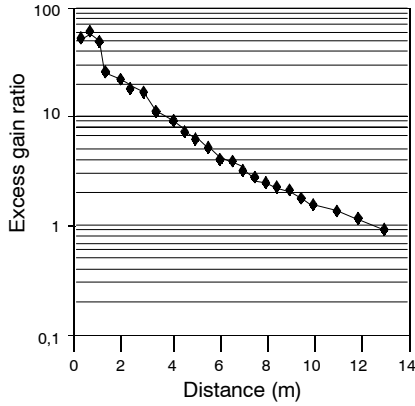

E3F2-R2R□4□ (Polarized retroreflective)

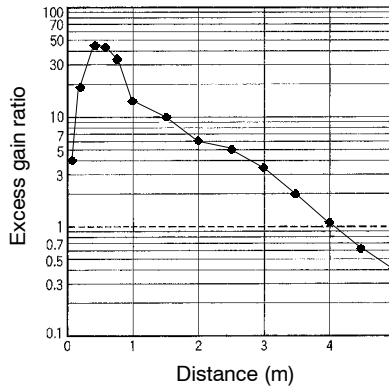

■ EXCESS GAIN VS. SET DISTANCE

E3F2-DS10Z□-N

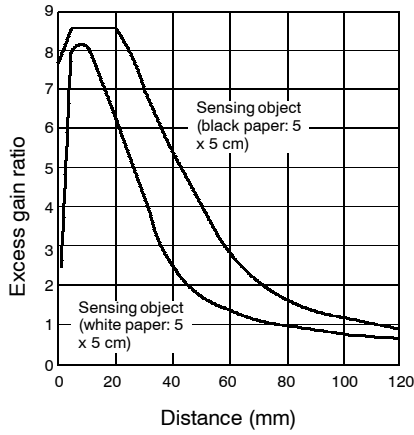

E3F2-DS10□4-N  
E3F2-DS10□4-P1

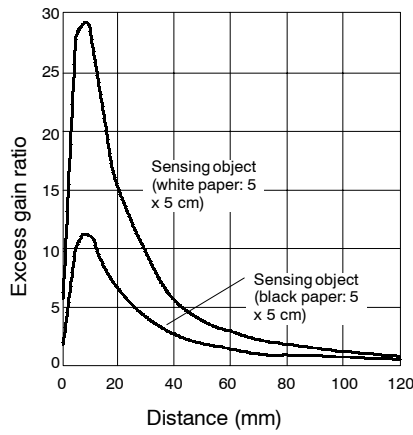

E3F2-DS30□4  
E3F2-DS30□4-P1

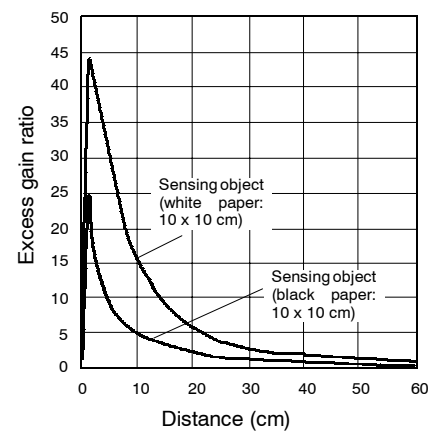

# Operation

## OUTPUT CIRCUITS

Configuration	Model	Connection method	Output transistor	Output circuit
NPN pre-wired	E3F2-7C4 E3F2-7C4-M E3F2-7C4-C E3F2-7C4-S E3F2-R2C4 E3F2-R2RC4-M E3F2-R2RC4-C E3F2-R2RC4-S E3F2-DS10C4-N E3F2-DS10C4-C E3F2-DS10C4-M E3F2-DS10C4-S E3F2-DS30C4 E3F2-DS30C4-M E3F2-DS30C4-S	Connect the pink and brown wires or open the pink wire.	ON when light is incident. (Light-ON)	
		Connect the pink and blue wires.	ON when light is interrupted. (Dark-ON)	
PNP pre-wired	E3F2-7B4 E3F2-7B4-M E3F2-7B4-C E3F2-7B4-S E3F2-R2B4 E3F2-R2RB4-M E3F2-R2RB4-C E3F2-R2RB4-S E3F2-DS10B4-N E3F2-DS10B4-M E3F2-DS10B4-C E3F2-DS10B4-S E3F2-DS30B4 E3F2-DS30B4-M E3F2-DS30B4-S	Connect the pink and brown wires or open the pink wire.	ON when light is incident. (Light-ON)	
		Connect the pink and blue wires.	ON when light is interrupted. (Dark-ON)	
NPN connector	E3F2-7C4-P1 E3F2-7C4-M1-M E3F2-7C4-M1-C E3F2-7C4-M1-S E3F2-R2C4-P1 E3F2-R2RC4-M1-M E3F2-R2RC4-M1-C E3F2-R2RC4-M1-S E3F2-DS10C4-P1 E3F2-DS10C4-M1-M E3F2-DS10C4-M1-C E3F2-DS10C4-M1-S E3F2-DS30C4-P1 E3F2-DS30C4-M1-M E3F2-DS30C4-M1-S	Connect the pink and brown wires or open the pink wire.	ON when light is incident. (Light-ON)	
		Connect the pink and blue wires.	ON when light is interrupted. (Dark-ON)	

Note: Terminal numbers are for connector types.

(This table continues on the next page.)



Operation Table - continued from previous page

Configuration	Model	Connection method	Output transistor	Output circuit
PNP connector	E3F2-7B4-P1 E3F2-7B4-M1-M E3F2-7B4-M1-C E3F2-7B4-M1-S E3F2-R2B4-P1 E3F2-R2RB4-M1-M E3F2-R2RB4-M1-C E3F2-R2RB4-M1-S E3F2-DS10B4-P1 E3F2-DS10B4-M1-M E3F2-DS10B4-M1-C E3F2-DS10B4-M1-S E3F2-DS30B4-P1 E3F2-DS30B4-M1-M E3F2-DS30B4-M1-S	Connect the pink and brown wires or open the pink wire.	ON when light is incident. (Light-ON)	
	Connect the pink and blue wires.	ON when light is interrupted. (Dark-ON)		
AC switching	E3F2-3Z1 E3F2-R2Z1 E3F2-DS10Z1-N	--- (Fixed)	ON when light is incident. (Light-ON)	
	E3F2-3Z2 E3F2-R2Z2 E3F2-DS10Z2-N		ON when light is interrupted. (Dark-ON)	

Note: Terminal numbers are for connector types.

## TIMING CHART

### Light-ON Mode

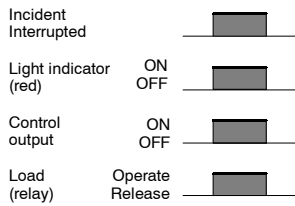

### Dark-ON Mode

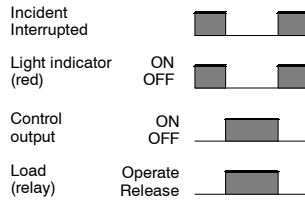

### Terminals/Connections

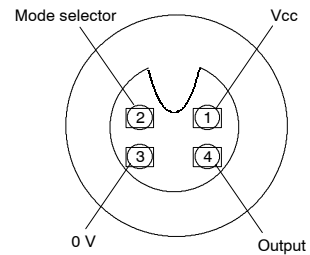

# Dimensions

Unit: mm (inch)

## PRE-LEADED DC MODELS

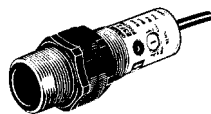

- E3F2-7□4-□
- E3F2-DS10□4-□
- E3F2-DS30□4
- E3F2-R2□4
- E3F2-R2R□4-□

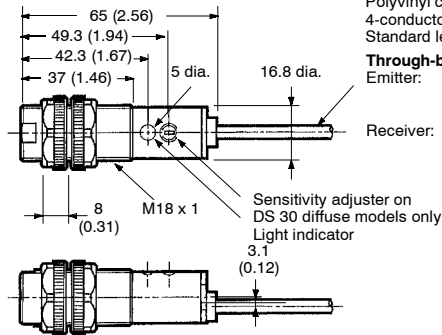
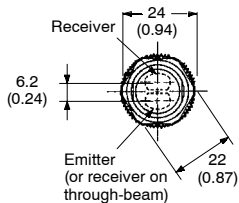

**Diffuse and Retroreflective (DC)**  
 Polyvinyl chloride-covered cord, 4-mm dia. (18/0.12), 4-conductor (brown, blue, black, and pink)  
 Standard length: 2 m

**Through-beam (DC)**  
 Emitter: Polyvinyl chloride-covered cord, 4-mm dia. (18/0.12), 2-conductor (brown and blue)  
 Standard length: 2 m  
 Receiver: Polyvinyl chloride-covered cord, 4-mm dia. (18/0.12), 4-conductor (brown, blue, black, and pink)  
 Standard length: 2 m

## CONNECTOR DC MODELS

- E3F2-7L-P1
- E3F2-7D-P1
- E3F2-7C4-P1, -M1-□
- E3F2-DS10□4-P1, -M1□
- E3F2-DS30□4-P1, -M1□
- E3F2-R2□-P1
- E3F2-R2R□-M1-□

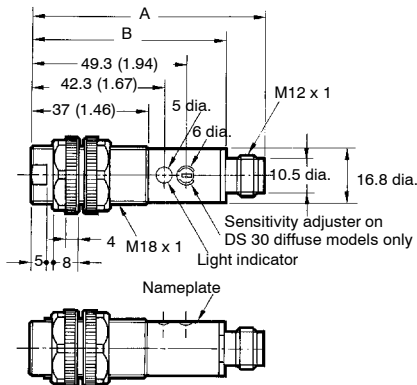
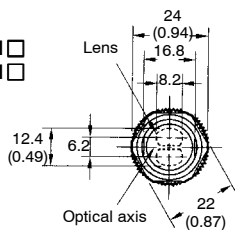

	Metal body	Plastic body
	E3F2-DS□□□□-□1	E3F2-DS30□4-P1
A	76 (2.99)	73 (2.87)
B	65.5 (2.58)	61.7 (2.43)

■ AC MODELS

E3F2-3Z1, E3F2-3Z2  
 E3F2-R2Z1, E3F2-R2Z2  
 E3F2-DS10Z1-N,  
 E3F2-DS10Z2-N

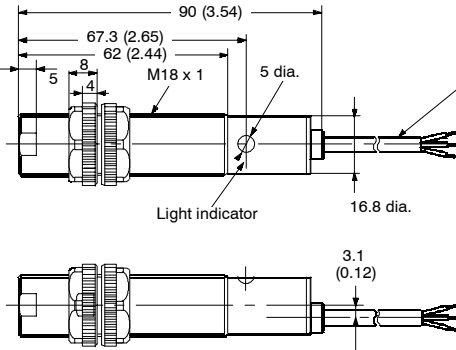
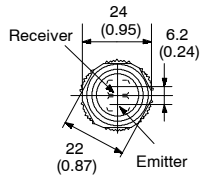
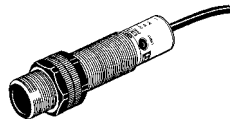

**Through-beam (AC)**

Emitter: Polyvinyl chloride-covered cord, 4-mm dia. (11/0.16), 2-conductor (brown and blue)  
 Standard length: 2 m

Receiver: Polyvinyl chloride-covered cord, 4-mm dia. (11/0.16), 3-conductor (brown, blue, and black)  
 Standard length: 2 m

**Diffuse and Retroreflective (AC)**

Vinyl insulated round cord, 4-mm dia. (11/0.16), 3-conductor (brown, blue, and black)  
 Standard length: 2 m

■ ACCESSORIES

**E39-R1 Reflector (included with retroreflective units)**

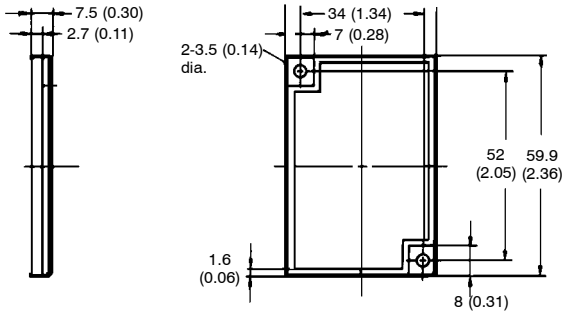

**E39-L7 Reflector Adapter (order separately)**

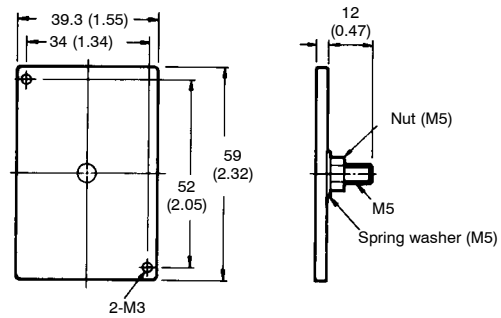

**E39-R3 Reflector (order separately)**

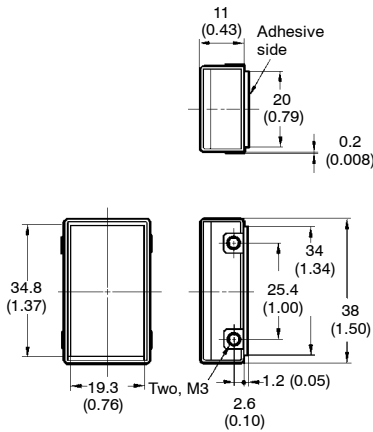

**Mounting Bracket for E39-R3 (included with E39-R3)**

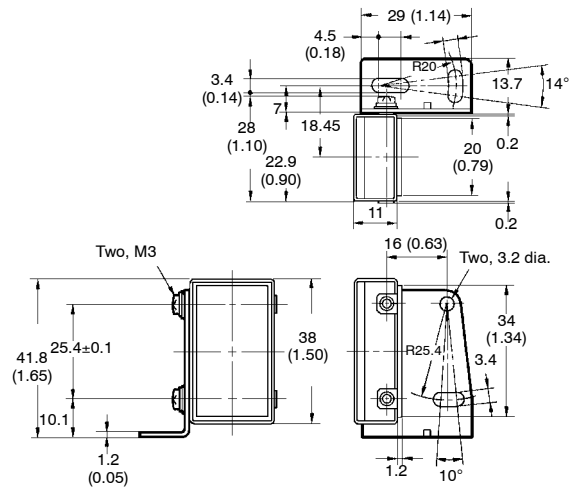

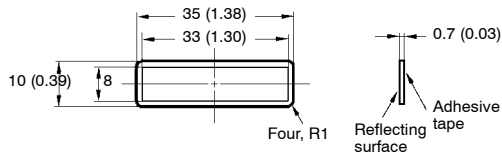
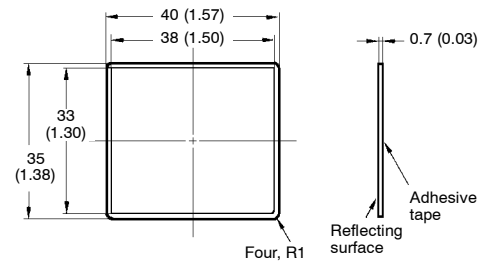
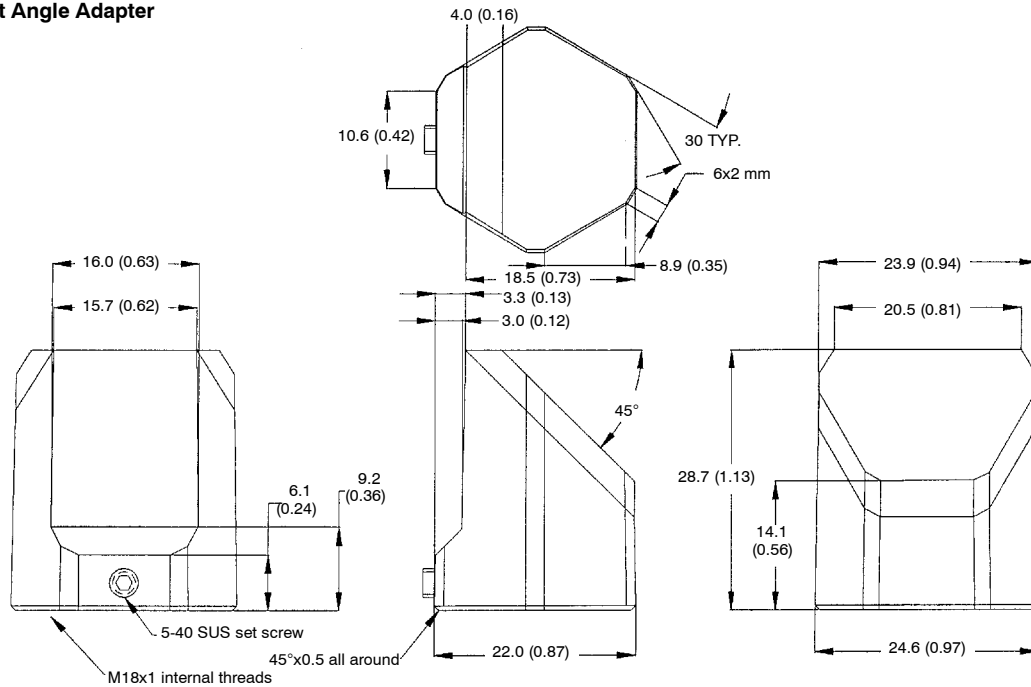
**E39-RSA Reflector****E39-RSB Reflector****E39-RU1 Right Angle Adapter****Mounting E39-RU1**

Do not exceed a torque value of 20 kg • cm (2.0 N • m, 17.4 in • lbs) when tightening the adapter onto the sensor.

Use a 1/16" (1.5 mm) hex key on the set screw to secure the adapter to the E3F2. Do not exceed a torque of 3.5 kg • cm (0.35 N • m, 3.0 in • lbs). When set properly, the set screw will still extend beyond the adapter wall. Make sure to loosen the set screw before removing the adapter from the sensor.

**Y92E-B18 Mounting Bracket**

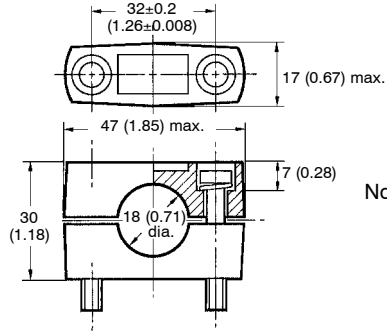
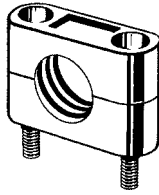

Note: Hexagonal nut: M5 x 32  
Material: plastic

**E39-F31 Lens Cap**

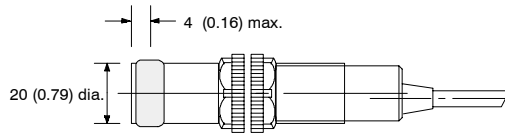
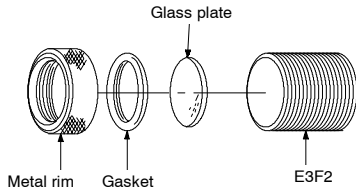

**OPTIONAL CONNECTOR CABLES**

**Straight Connector Cable**

Y96E-44SD□

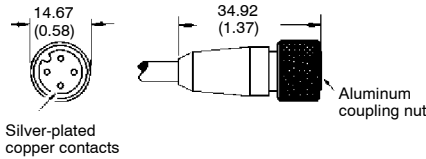

22 AWG, PVC jacketed cable rated for 300 V, 90°C:  
2 m (6.56 ft) length for Y96E-44SD2  
5 m (16.40 ft) length for Y96E-44SD5  
10 m (32.81 ft) length for Y96E-44SD10

**Right Angle Connector Cable**

Y96E-44RD□

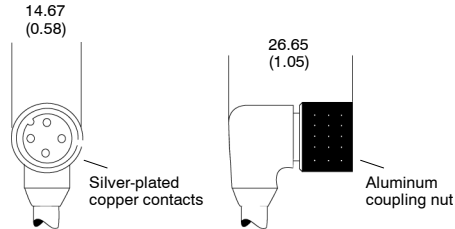

22 AWG, PVC jacketed cable rated for 300 V, 90°C:  
2 m (6.56 ft) length for Y96E-44RD2  
5 m (16.40 ft) length for Y96E-44RD5  
10 m (32.81 ft) length for Y96E-44RD10

Note: Cable may be extended to a maximum of 200 m (656 ft.)

**Terminals/Connections**

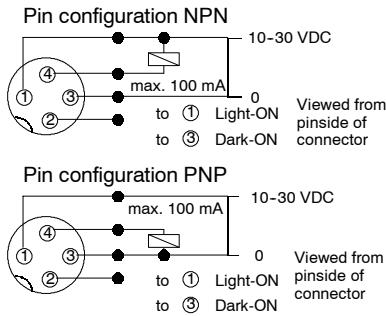

**Assembly Directions**

Insert the M12 threaded end of the sensor into socket of connector so that the notch correctly aligns the pins. Tighten the coupling nut by hand, not using a tool, until all the threads on the rear of the sensor are covered. This assures a positive connection, important for installations with vibration.

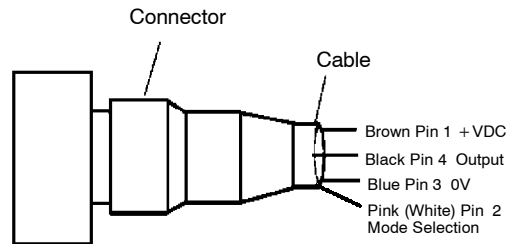

Note: Water tightness with connector is only valid when authorized connections are used. Cordset wire colors are shown in parentheses.

## Precautions

If the input/output lines of the Photoelectric Sensor are placed in the same conduit or duct as power lines or high-voltage lines, the Photoelectric Sensor could be induced to malfunction, or even be damaged, by electrical noise. Separate the wiring, or use shielded lines as input/output lines to the Photoelectric Sensor.

Do not subject the Photoelectric Sensor to excessive shock when mounting, in keeping with IEC60529 IP66 standards.

Do not connect the black wire to the brown wire without a load. Direct connection of these wires may damage the Photoelectric Sensor (AC switching type).

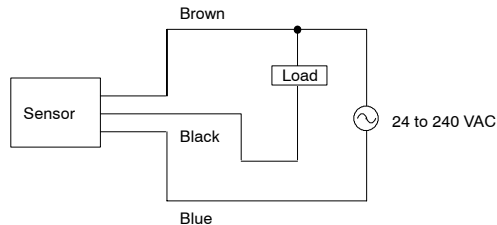

### WARNING

The E3F2 Photoelectric Sensor is not a safety component for ensuring the safety of people which is defined in EC Directive (91/368/EEC) and covered by separate European standards or by any other regulations or standards.

When using the Photoelectric Sensor in the vicinity of an inverter motor, be sure to connect the ground wire of the motor to earth. Failure to ground the motor may result in malfunction of the Sensor.

When using the Photoelectric Sensor at temperatures over 45°C, the load current must be within the rated value shown in the figure below.

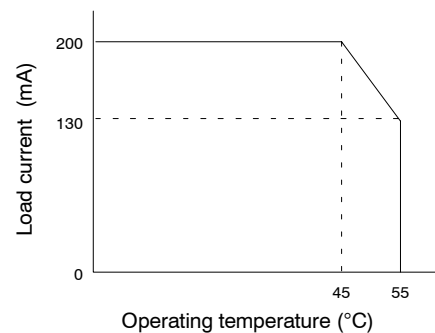

### ■ MOUNTING

Do not exceed a torque of

- 2.0 N • m {20 kgf • cm} 17.7 in • lb when tightening mounting nuts for plastic models.
- 20.0 N • m {200 kgf • cm} 177 in • lb when tightening mounting nuts for metal models.

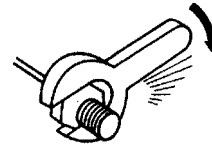

**NOTE: DIMENSIONS SHOWN ARE IN MILLIMETERS. To convert millimeters to inches divide by 25.4.**

# OMRON®

**OMRON ELECTRONICS LLC**

One East Commerce Drive  
Schaumburg, IL 60173

**1-800-55-OMRON**

**OMRON ON-LINE**

Global - <http://www.omron.com>

USA - <http://www.omron.com/oei>

Canada - <http://www.omron.com/oci>

**OMRON CANADA, INC.**

885 Milner Avenue  
Scarborough, Ontario M1B 5V8

**416-286-6465**