

Keypad modules for Power Panel T- Series and C-Series

User's manual

Version: **1.70 (March 2020)**

Order no.: **4XP0043.00-00B, 4XP0043.00-00W,
4XP0057.00-00B, 4XP0057.00-00W,
4XP0070.00-00B, 4XP0070.00-00W,
4XP0101.00-00B, 4XP0101.00-00W;**

Translation of the original documentation

All values in this manual are current as of its creation. We reserve the right to change the contents of this manual without notice. B&R Industrial Automation GmbH is not liable for technical or editorial errors and defects in this manual. In addition, B&R Industrial Automation GmbH assumes no liability for damages that are directly or indirectly attributable to the delivery, performance or use of this material. We point out that the software and hardware designations and brand names of the respective companies used in this document are subject to general trademark, brand or patent protection.

1	General information.....	4
1.1	Document history.....	4
1.2	General safety guidelines.....	5
1.2.1	Intended use.....	5
1.2.2	Protection against electrostatic discharge.....	5
1.2.2.1	Packaging.....	5
1.2.2.2	Regulations for proper ESD handling.....	5
1.2.3	Regulations and measures.....	5
1.2.4	Transport and storage.....	6
1.2.5	Installation.....	6
1.2.6	Operation.....	6
1.2.6.1	Protection against contact with electrical parts.....	6
1.2.6.2	Ambient conditions - Dust, moisture, aggressive gases.....	6
1.2.6.3	Programs, viruses and malicious programs.....	6
1.2.7	Environmentally friendly disposal.....	7
1.2.7.1	Separation of materials.....	7
1.2.8	Cybersecurity disclaimer for products.....	7
1.3	Information about this document.....	7
1.3.1	Organization of notices.....	8
1.3.2	Guidelines.....	8
1.4	Overview.....	9
2	Introduction.....	10
2.1	Information about this user's manual.....	10
2.2	Description of the keypad modules.....	10
3	Individual components.....	11
3.1	To fit Power Panel T-Series / C-Series 4.3".....	11
3.1.1	4XP0043.00-00B.....	11
3.1.1.1	General.....	11
3.1.1.2	Order data.....	11
3.1.1.3	Views - 4XP0043.00-00B.....	12
3.1.1.4	Technical data.....	13
3.1.1.5	Panel overlay design.....	14
3.1.1.6	Adhesive device label.....	14
3.1.2	4XP0043.00-00W.....	15
3.1.2.1	General.....	15
3.1.2.2	Order data.....	15
3.1.2.3	Views - 4XP0043.00-00W.....	16
3.1.2.4	Technical data.....	17
3.1.2.5	Panel overlay design.....	18
3.1.2.6	Adhesive device label.....	18
3.1.3	4XP0043.00-00x - Dimensions.....	19
3.2	To fit Power Panel T-Series / C-Series 5.7".....	20
3.2.1	4XP0057.00-00B.....	20
3.2.1.1	General.....	20
3.2.1.2	Order data.....	20
3.2.1.3	Views - 4XP0057.00-00B.....	21
3.2.1.4	Technical data.....	22
3.2.1.5	Panel overlay design.....	23
3.2.1.6	Adhesive device label.....	23
3.2.2	4XP0057.00-00W.....	24
3.2.2.1	General.....	24
3.2.2.2	Order data.....	24
3.2.2.3	Views - 4XP0057.00-00W.....	25
3.2.2.4	Technical data.....	26
3.2.2.5	Panel overlay design.....	27

3.2.2.6 Adhesive device label.....	27
3.2.3 4XP0057.00-00x - Dimensions.....	28
3.3 To fit Power Panel T-Series / C-Series 7".....	29
3.3.1 4XP0070.00-00B.....	29
3.3.1.1 General.....	29
3.3.1.2 Order data.....	29
3.3.1.3 Views - 4XP0070.00-00B.....	30
3.3.1.4 Technical data.....	31
3.3.1.5 Panel overlay design.....	32
3.3.1.6 Adhesive device label.....	32
3.3.2 4XP0070.00-00W.....	33
3.3.2.1 General.....	33
3.3.2.2 Order data.....	33
3.3.2.3 Views - 4XP0070.00-00W.....	34
3.3.2.4 Technical data.....	35
3.3.2.5 Panel overlay design.....	36
3.3.2.6 Adhesive device label.....	36
3.3.3 4XP0070.00-00x - Dimensions.....	37
3.4 To fit Power Panel T-Series / C-Series 10.1".....	38
3.4.1 4XP0101.00-00B.....	38
3.4.1.1 General.....	38
3.4.1.2 Order data.....	38
3.4.1.3 Views - 4XP0101.00-00B.....	39
3.4.1.4 Technical data.....	40
3.4.1.5 Panel overlay design.....	41
3.4.1.6 Adhesive device label.....	41
3.4.2 4XP0101.00-00W.....	42
3.4.2.1 General.....	42
3.4.2.2 Order data.....	42
3.4.2.3 Views - 4XP0101.00-00W.....	43
3.4.2.4 Technical data.....	44
3.4.2.5 Panel overlay design.....	45
3.4.2.6 Adhesive device label.....	45
3.4.3 4XP0101.00-00x - Dimensions.....	46
4 Features - Technical data.....	47
4.1 +24 VDC power supply.....	47
4.2 X2X interface.....	47
4.3 LED status indicator.....	47
5 Key and LED configurations.....	48
6 Cleaning.....	50
6.1 Surface resistance of the panel overlay.....	50
7 EC declaration of conformity.....	51

1 General information

1.1 Document history

Version	Date	Change
1.00	2014-10-17	<ul style="list-style-type: none"> • First version
1.10	2016-05-09	<ul style="list-style-type: none"> • Removed TBD. • Added power consumption information.
1.20	2018-03-14	Updated book. <ul style="list-style-type: none"> • Corrected certifications in technical data.
1.30 (Rev. B0 and later)	2018-08-13	Updated book. <ul style="list-style-type: none"> • New power supply connector • New dimension diagrams • New photos
1.40 (Rev. B0 and later)	2018-11-29	Updated manual. <ul style="list-style-type: none"> • Editorial revisions. • Changed technical data. • Updated adhesive device label.
1.50 (Rev. B0 and later)	2018-12-10	Updated manual. <ul style="list-style-type: none"> • Changed tightening torque from max. 0.6 to max. 0.4 Nm.
1.60 (Rev. B0 and later)	2019-03-13	Updated manual. <ul style="list-style-type: none"> • Updated technical data.
1.70	March 2020	Updated manual. <ul style="list-style-type: none"> • Added notes and minimum wire cross section in section "+24 VDC power supply" on page 47. • Updated chapter "Cleaning" on page 50.

1.2 General safety guidelines

1.2.1 Intended use

Programmable logic controllers, operating and monitoring devices (e.g. industrial PCs, Power Panels, Mobile Panels) as well as uninterruptible power supplies from B&R have been designed, developed and manufactured for normal use in industry. They have not been designed, developed and manufactured for use that involves fatal risks or hazards that could result in death, injury, serious physical harm or other loss without the assurance of exceptionally stringent safety precautions. In particular, this includes the use of these systems to monitor nuclear reactions in nuclear power plants, flight control systems, air traffic control, the control of mass transport vehicles, medical life support systems and the control of weapon systems.

1.2.2 Protection against electrostatic discharge

Electrical assemblies that can be damaged by electrostatic discharge (ESD) must be handled accordingly.

1.2.2.1 Packaging

- **Electrical assemblies with housing:**
Do not require special ESD packaging but must be handled properly (see "Electrical assemblies with housing").
- **Electrical assemblies without housing:**
Are protected by ESD-suitable packaging.

1.2.2.2 Regulations for proper ESD handling

Electrical assemblies with housing

- Do not touch the connector contacts of connected cables.
- Do not touch the contact tips on circuit boards.

Electrical assemblies without housing

The following applies in addition to "Electrical assemblies with housing":

- All persons handling electrical assemblies and devices in which electrical assemblies are installed must be grounded.
- Assemblies are only permitted to be touched on the narrow sides or front plate.
- Always place assemblies on suitable surfaces (ESD packaging, conductive foam, etc.). Metallic surfaces are not suitable surfaces!
- Assemblies must not be subjected to electrostatic discharges (e.g. due to charged plastics).
- A minimum distance of 10 cm from monitors or television sets must be maintained.
- Measuring instruments and devices must be grounded.
- Test probes of floating potential measuring instruments must be discharged briefly on suitable grounded surfaces before measurement.

Individual components

- ESD protective measures for individual components are implemented throughout B&R (conductive floors, shoes, wrist straps, etc.).
- The increased ESD protective measures for individual components are not required for handling B&R products at customer locations.

1.2.3 Regulations and measures

Electronic devices are generally not failsafe. If the programmable logic controller, operating or control device or uninterruptible power supply fails, the user is responsible for ensuring that connected devices (such as motors) are brought to a safe state.

When using programmable logic controllers as well as when using operating and monitoring devices as control systems in conjunction with a Soft PLC (e.g. B&R Automation Runtime or similar product) or Slot PLC (e.g. B&R LS251 or similar product), the safety measures that apply to industrial controllers (protection by protective equipment such as emergency stops) must be observed in accordance with applicable national and international regulations. This also applies to all other connected devices, such as drives.

All work such as installation, commissioning and servicing are only permitted to be carried out by qualified personnel. Qualified personnel are persons who are familiar with the transport, installation, assembly, commissioning and operation of the product and have the appropriate qualifications for their job (e.g. IEC 60364). National accident prevention regulations must be observed.

The safety guidelines, information about connection conditions (nameplate and documentation) and limit values specified in the technical data must be read carefully before installation and commissioning and must be strictly observed.

1.2.4 Transport and storage

During transport and storage, devices must be protected against undue stress (mechanical stress, temperature, humidity, aggressive atmosphere).

1.2.5 Installation

- The devices are not ready for use and must be installed and wired according to the requirements of this documentation in order to comply with EMC limit values.
- Installation must be carried out according to the documentation using suitable equipment and tools.
- Devices are only permitted to be installed by qualified personnel when the power is switched off. The control cabinet must first be disconnected from the power supply and secured against being switched on again.
- General safety regulations and national accident prevention regulations must be observed.
- The electrical installation must be carried out in accordance with relevant regulations (e.g. wire cross section, fuse protection, protective ground connection).

1.2.6 Operation

1.2.6.1 Protection against contact with electrical parts

In order to operate programmable logic controllers, operating and monitoring devices and uninterruptible power supplies, it is necessary for certain components to carry dangerous voltages over 42 VDC. Touching one of these components can result in a life-threatening electric shock. There is a risk of death, serious injury or damage to property.

Before switching on programmable logic controllers, operating and monitoring devices and uninterruptible power supplies, it must be ensured that the housing is properly connected to ground potential (PE rail). The ground connection must also be made if the operating and monitoring device and uninterruptible power supply are only connected for testing purposes or only operated for a short time!

Before switching on, live parts must be securely covered. All covers must be kept closed during operation.

1.2.6.2 Ambient conditions - Dust, moisture, aggressive gases

The use of operating and monitoring devices (e.g. industrial PCs, Power Panels, Mobile Panels) and uninterruptible power supplies in dusty environments must be avoided. This can otherwise result in dust deposits that affect the functionality of the device, especially in systems with active cooling (fans), which may no longer ensure sufficient cooling.

The presence of aggressive gases in the environment can also result in malfunctions. In combination with high temperature and relative humidity, aggressive gases – for example with sulfur, nitrogen and chlorine components – trigger chemical processes that can very quickly impair or damage electronic components. Blackened copper surfaces and cable ends in existing installations are indicators of aggressive gases.

When operated in rooms with dust and condensation that can endanger functionality, operating and monitoring devices such as Automation Panels or Power Panels are protected on the front against the ingress of dust and moisture when installed correctly (e.g. cutout installation). The back of all devices must be protected against the ingress of dust and moisture, however, or the dust deposits must be removed at suitable intervals.

1.2.6.3 Programs, viruses and malicious programs

Any data exchange or installation of software using data storage media (e.g. floppy disk, CD-ROM, USB flash drive) or via networks or the Internet poses a potential threat to the system. It is the direct responsibility of the user to avert these dangers and to take appropriate measures such as virus protection programs and firewalls to protect against them and to use only software from trustworthy sources.

1.2.7 Environmentally friendly disposal

All programmable logic controllers, operating and monitoring devices and uninterruptible power supplies from B&R are designed to have as little impact on the environment as possible.

1.2.7.1 Separation of materials

To ensure that devices can be recycled in an environmentally friendly manner, it is necessary to separate out the different materials.

Component	Disposal
Programmable logic controllers Operating and monitoring devices Uninterruptible power supplies Batteries and rechargeable batteries Cables	Electronics recycling
Paper/Cardboard packaging	Paper/Cardboard recycling
Plastic packaging material	Plastic recycling

Disposal must be carried out in accordance with applicable legal regulations.

1.2.8 Cybersecurity disclaimer for products

B&R products communicate via a network interface and were developed for secure connection with internal and, if necessary, other networks such as the Internet.

Information:

In the following, B&R products are referred to as "product" and all types of networks (e.g. internal networks and the Internet) are referred to as "network".

It is the sole responsibility of the customer to establish and continuously ensure a secure connection between the product and the network. In addition, appropriate security measures must be implemented and maintained to protect the product and entire network from any security breaches, unauthorized access, interference, digital intrusion, data leakage and/or theft of data or information.

B&R Industrial Automation GmbH and its subsidiaries are not liable for damages and/or losses in connection with such security breaches, unauthorized access, interference, digital intrusion, data leakage and/or theft of data or information.

The aforementioned suitable security measures include, for example:

- Segmentation of the network (e.g. separation of the IT network from the control network¹⁾)
- Use of firewalls
- Use of authentication mechanisms
- Encryption of data
- Use of anti-malware software

Before B&R releases products or updates, they are subjected to appropriate functional testing. Independently of this, we recommend that our customers develop their own test processes in order to be able to check the effects of changes in advance. Such changes include, for example:

- Installation of product updates
- Significant system modifications such as configuration changes
- Import of updates or patches for third-party software (non-B&R software)
- Hardware replacement

These tests should ensure that implemented security measures remain effective and that systems in the customer's environment behave as expected.

1.3 Information about this document

This document is not intended for end customers! The safety guidelines required for end customers must be incorporated into the operating instructions for end customers in the respective national language by the machine manufacturer or system provider.

¹⁾ The term "control network" refers to computer networks used to connect control systems. The control network can be divided into zones, and there can be several separate control networks within a company or site. The term "control systems" refers to all types of B&R products such as controllers (e.g. X20), HMI systems (e.g. Power Panel T30), process control systems (e.g. APROL) and supporting systems such as engineering workstations with Automation Studio.

1.3.1 Organization of notices

Safety notices

Contain **only** information that warns of dangerous functions or situations.

Signal word	Description
Danger!	Failure to observe these safety guidelines and notices will result in death, severe injury or substantial damage to property.
Warning!	Failure to observe these safety guidelines and notices can result in death, severe injury or substantial damage to property.
Caution!	Failure to observe these safety guidelines and notices can result in minor injury or damage to property.
Notice!	Failure to observe these safety guidelines and notices can result in damage to property.

General notices

Contain **useful** information for users and instructions for avoiding malfunctions.

Signal word	Description
Information:	Useful information, application tips and instructions for avoiding malfunctions.

1.3.2 Guidelines

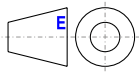

European dimension standards apply to all dimension diagrams.

All dimensions in mm.

Unless otherwise specified, the following general tolerances apply:

Nominal dimension range	General tolerance per DIN ISO 2768 medium
Up to 6 mm	±0.1 mm
Over 6 to 30 mm	±0.2 mm
Over 30 to 120 mm	±0.3 mm
Over 120 to 400 mm	±0.5 mm
Over 400 to 1000 mm	±0.8 mm

1.4 Overview

2 Introduction

2.1 Information about this user's manual

This user's manual contains all necessary information regarding the keypad modules for the T-Series and C-Series.

2.2 Description of the keypad modules

Keypad modules with B&R's patented illuminated ring keys are the perfect complement to B&R's operator panels.



3 Individual components

3.1 To fit Power Panel T-Series / C-Series 4.3"

3.1.1 4XP0043.00-00B

3.1.1.1 General

- Plastic front with inset edge protection for the panel overlay
- Panel overlay design in anthracite gray
- Width to fit Power Panel T-Series / C-Series 4.3"
- IP65 protection on front, IP20 protection on back
- Fastened using retaining clips
- Keypad with 3 B&R illuminated ring keys
- All keys labeled with slide-in labels and with 4-color illumination (2x red, yellow, green, white and 1x red, yellow, green blue)
- Controlled by B&R X2X electronics, 24 VDC power supply, connected via terminal block

3.1.1.2 Order data

Model number	Short description	Figure
	Keypad modules	
4XP0043.00-00B	X2X keypad module, anthracite, 3 B&R illuminated ring keys, with 4-color illumination: Green, yellow, red, white (2 keys) / green, yellow, red, blue (1 key), X2X interface, 24 VDC, terminal blocks included in delivery, width suitable for 4.3" Power Panel T/C	
	Included in delivery	
	Terminal blocks	
0TB6103.4100	Accessory terminal block, 3-pin (3.81), cage clamp terminal block 1.5 mm ²	
0TB6108.4100	Accessory terminal block, 8-pin (3.81), cage clamp terminal block 1.5 mm ²	

Table 1: 4XP0043.00-00B - Order data

3.1.1.3 Views - 4XP0043.00-00B

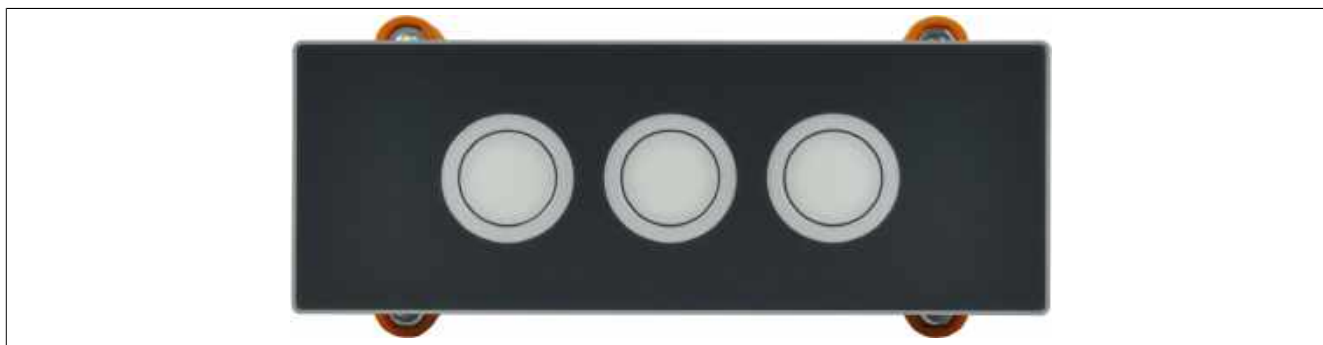

Figure 1: 4XP0043.00-00B - Front view



Figure 2: 4XP0043.00-00B - Rear view



Figure 3: 4XP0043.00-00B - Oblique view



Figure 4: 4XP0043.00-00B - Side view

3.1.1.4 Technical data

Model number	4XP0043.00-00B
General information	
LEDs	1x Run (green), 1x Error (red)
Key labels	With slide-in labels
Certifications	
CE	Yes
UL	cULus E115267 Industrial control equipment
Interfaces	
X2X	
Type	X2X slave
Variant	8-pin male multipoint connector
Internal bus power supply	Yes
Distance between 2 stations	100 m
Electrical isolation	No
Keys	
Illuminated ring keys	3x B&R illuminated ring keys (round)
Illuminated ring keys	
Color	With 4-color illumination, green, yellow, red, white (2 keys) / green, yellow, red, blue (1 key)
Service life	>1,000,000 actuations
Electrical properties	
Nominal voltage	24 VDC \pm 25%, galvanically isolated
Inrush current	Max. 20 A for <1 ms
Power consumption	Max. 0.35 A
Operating conditions	
Degree of protection per EN 60529	Front: IP65 Back: IP20
Degree of protection per UL 50	Front: Type 4X indoor use only
Ambient conditions	
Temperature	
Operation	0 to +50°C
Storage	-20 to +60°C
Transport	-20 to +60°C
Relative humidity	
Operation	T \leq 40°C: 5 to 90%, non-condensing T > 40°C: <75%, non-condensing
Storage	T \leq 40°C: 5 to 90%, non-condensing T > 40°C: <75%, non-condensing
Transport	T \leq 40°C: 5 to 90%, non-condensing T > 40°C: <75%, non-condensing
Elevation	
Operation	Max. 3000 m
Mechanical properties	
Housing	
Material	Plastic
Front	
Frame	Plastic
Panel overlay	
Material	Polyester
Design	Anthracite
Gasket	Flat gasket around display front
Dimensions	
Width	140 mm
Height	52 mm
Depth	40.4 mm
Weight	116 g

Table 2: 4XP0043.00-00B - Technical data

3.1.1.5 Panel overlay design

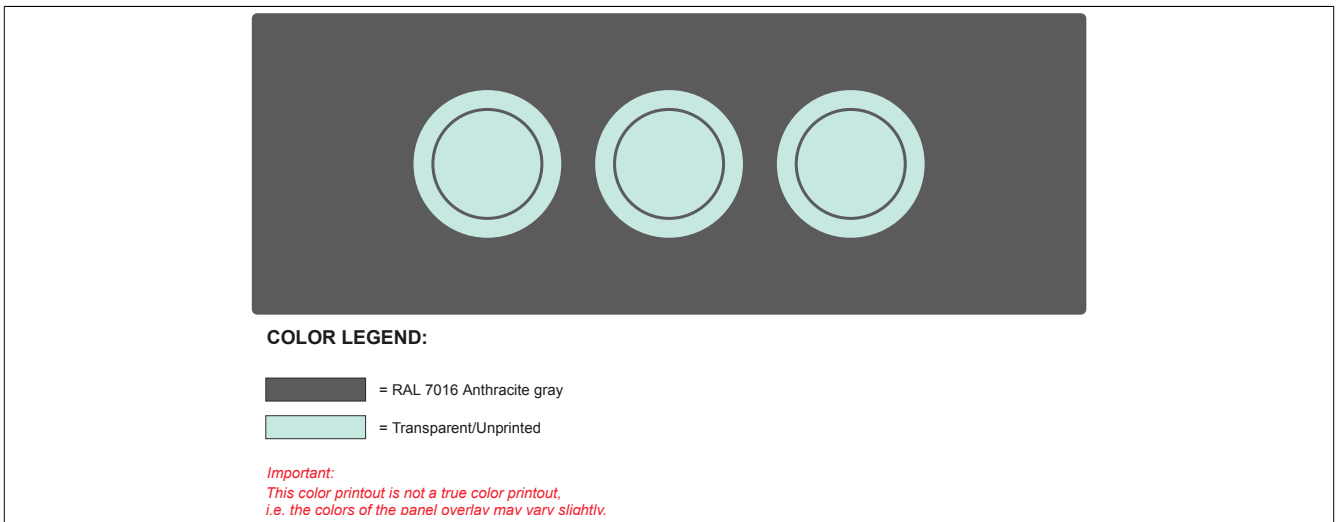

Figure 5: 4XP0043.00-00B - Panel overlay design

Information:

- To make exchanging the slide-in labels easier, it is recommended to do so before mounting the device.
- A slide-in label template can be downloaded from the B&R website (www.br-automation.com).

3.1.1.6 Adhesive device label

This adhesive label is attached to the back as a way to identify the interfaces.



Figure 6: Adhesive device label

3.1.2 4XP0043.00-00W

3.1.2.1 General

- Plastic front with inset edge protection for the panel overlay
- Panel overlay design in white aluminum
- Width to fit Power Panel T-Series / C-Series 4.3"
- IP65 protection on front, IP20 protection on back
- Fastened using retaining clips
- Keypad with 3 B&R illuminated ring keys
- All keys labeled with slide-in labels and with 4-color illumination (2x red, yellow, green, white and 1x red, yellow, green blue)
- Controlled by B&R X2X electronics, 24 VDC power supply, connected via terminal block

3.1.2.2 Order data

Model number	Short description	Figure
	Keypad modules	
4XP0043.00-00W	X2X keypad module, white aluminum, 3 B&R illuminated ring keys, with 4-color illumination: Green, yellow, red, white (2 keys) / green, yellow, red, blue (1 key), X2X interface, 24 VDC, terminal blocks included in delivery, width suitable for 4.3" Power Panel T/C	
	Included in delivery	
	Terminal blocks	
0TB6103.4100	Accessory terminal block, 3-pin (3.81), cage clamp terminal block 1.5 mm ²	
0TB6108.4100	Accessory terminal block, 8-pin (3.81), cage clamp terminal block 1.5 mm ²	

Table 3: 4XP0043.00-00W - Order data

3.1.2.3 Views - 4XP0043.00-00W

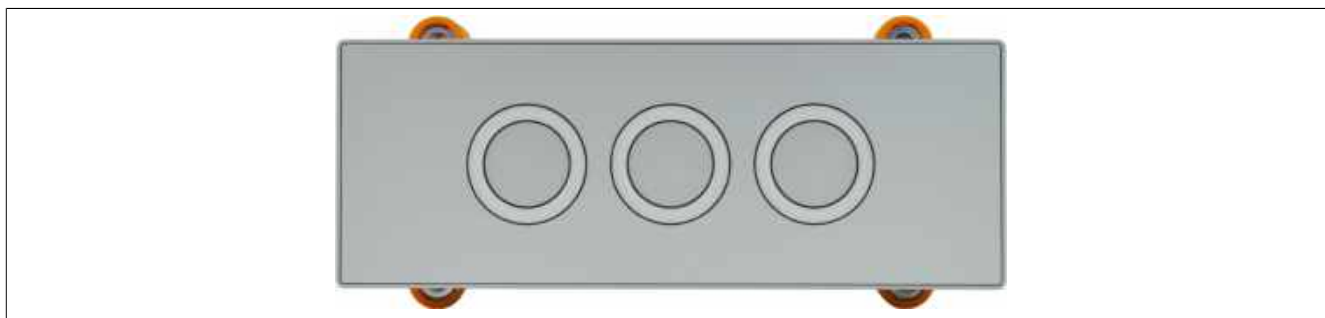

Figure 7: 4XP0043.00-00W - Front view



Figure 8: 4XP0043.00-00W - Rear view



Figure 9: 4XP0043.00-00W - Oblique view



Figure 10: 4XP0043.00-00W - Side view

3.1.2.4 Technical data

Model number	4XP0043.00-00W
General information	
LEDs	1x Run (green), 1x Error (red)
Key labels	With slide-in labels
Certifications	
CE	Yes
UL	cULus E115267 Industrial control equipment
Interfaces	
X2X	
Type	X2X slave
Variant	8-pin male multipoint connector
Internal bus power supply	Yes
Distance between 2 stations	100 m
Electrical isolation	No
Keys	
Illuminated ring keys	3x B&R illuminated ring keys (round)
Illuminated ring keys	
Color	With 4-color illumination, green, yellow, red, white (2 keys) / green, yellow, red, blue (1 key)
Service life	>1,000,000 actuations
Electrical properties	
Nominal voltage	24 VDC \pm 25%, galvanically isolated
Inrush current	Max. 20 A for <1 ms
Power consumption	Max. 0.35 A
Operating conditions	
Degree of protection per EN 60529	Front: IP65 Back: IP20
Degree of protection per UL 50	Front: Type 4X indoor use only
Ambient conditions	
Temperature	
Operation	0 to +50°C
Storage	-20 to +60°C
Transport	-20 to +60°C
Relative humidity	
Operation	T \leq 40°C: 5 to 90%, non-condensing T > 40°C: <75%, non-condensing
Storage	T \leq 40°C: 5 to 90%, non-condensing T > 40°C: <75%, non-condensing
Transport	T \leq 40°C: 5 to 90%, non-condensing T > 40°C: <75%, non-condensing
Elevation	
Operation	Max. 3000 m
Mechanical properties	
Housing	
Material	Plastic
Front	
Frame	Plastic
Panel overlay	
Material	Polyester
Design	White aluminum
Gasket	Flat gasket around display front
Dimensions	
Width	140 mm
Height	52 mm
Depth	40.4 mm
Weight	116 g

Table 4: 4XP0043.00-00W - Technical data

3.1.2.5 Panel overlay design

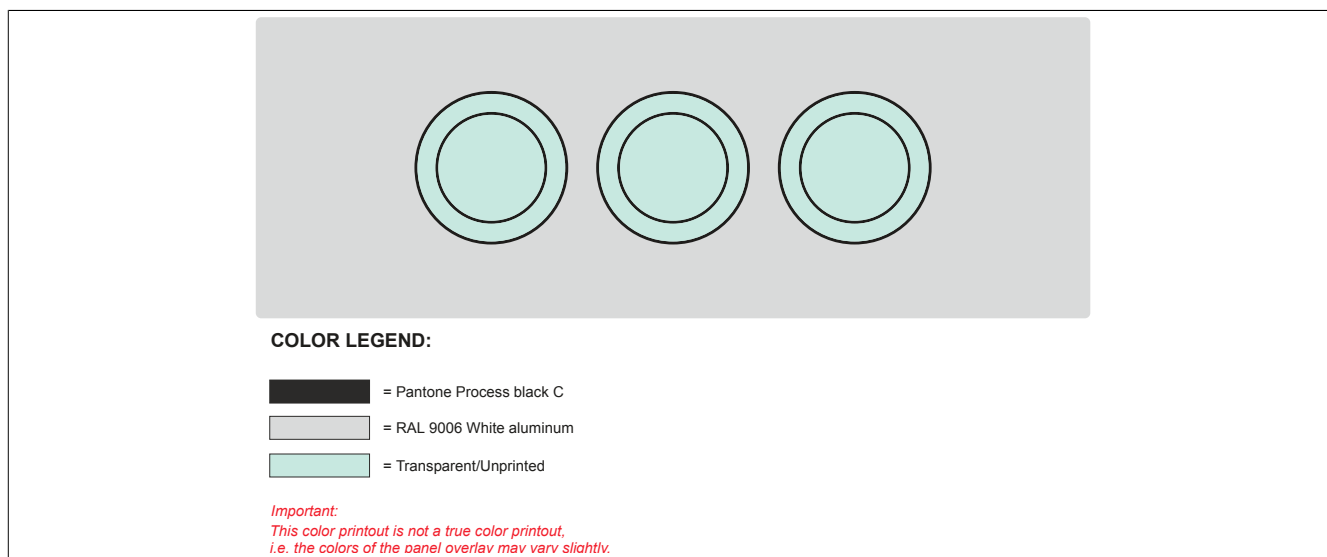

Figure 11: 4XP0043.00-00W - Panel overlay design

Information:

- To make exchanging the slide-in labels easier, it is recommended to do so before mounting the device.
- A slide-in label template can be downloaded from the B&R website (www.br-automation.com).

3.1.2.6 Adhesive device label

This adhesive label is attached to the back as a way to identify the interfaces.



Figure 12: Adhesive device label

3.1.3 4XP0043.00-00x - Dimensions

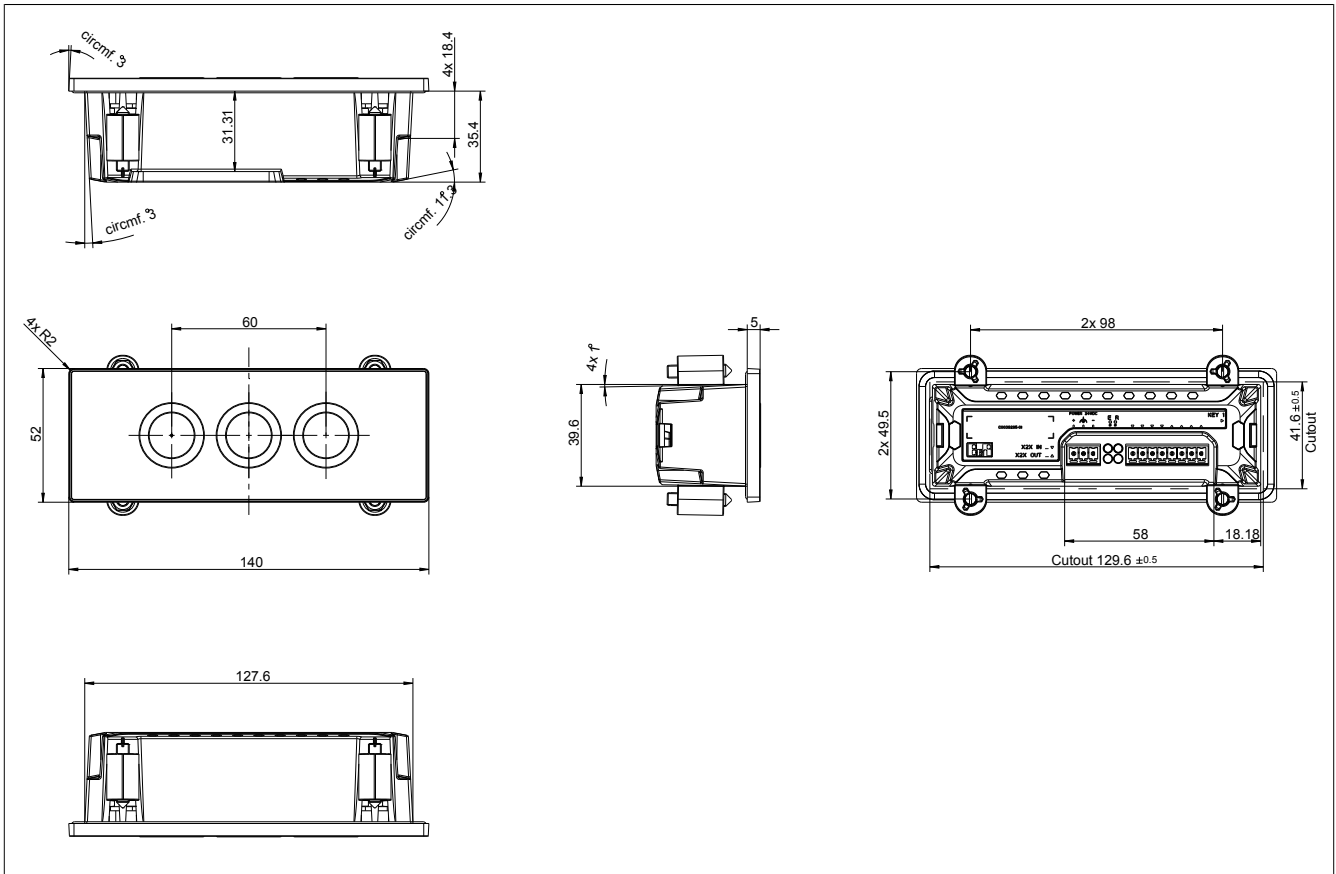

Figure 13: 4XP0043.00-00x - Dimensions

Max. control cabinet thickness: 6 mm

Cutout dimension: 129.6 ± 0.5 mm x 41.6 ± 0.5 mm

Minimum distance between two modules: 10 mm

Notice!

- Ensure that the slide-in label does not become caught when installing the module.
- The keypad must be installed using the retaining clips included in delivery (with a maximum tightening torque of 0.4 Nm).
- IP65 protection is only provided when the surface is flush and smooth.
- The customer is responsible for providing strain relief for the cable. A slot for a cable tie is provided on both sides of the module for this purpose.

3.2 To fit Power Panel T-Series / C-Series 5.7"

3.2.1 4XP0057.00-00B

3.2.1.1 General

- Plastic front with inset edge protection for the panel overlay
- Panel overlay design in anthracite gray
- Width to fit Power Panel T-Series / C-Series 5.7"
- IP65 protection on front, IP20 protection on back
- Fastened using retaining clips
- Keypad with 5 B&R illuminated ring keys
- All keys labeled with slide-in labels and with 4-color illumination (4x red, yellow, green, white and 1x red, yellow, green blue)
- Controlled by B&R X2X electronics, 24 VDC power supply, connected via terminal block

3.2.1.2 Order data

Model number	Short description	Figure
	Keypad modules	
4XP0057.00-00B	X2X keypad module, anthracite, 5 B&R illuminated ring keys, with 4-color illumination: Green, yellow, red, white (4 keys) / green, yellow, red, blue (1 key), X2X interface, 24 VDC, terminal blocks included in delivery, width suitable for 5.7" Power Panel T/C	
	Included in delivery	
	Terminal blocks	
0TB6103.4100	Accessory terminal block, 3-pin (3.81), cage clamp terminal block 1.5 mm ²	
0TB6108.4100	Accessory terminal block, 8-pin (3.81), cage clamp terminal block 1.5 mm ²	

Table 5: 4XP0057.00-00B - Order data

3.2.1.3 Views - 4XP0057.00-00B

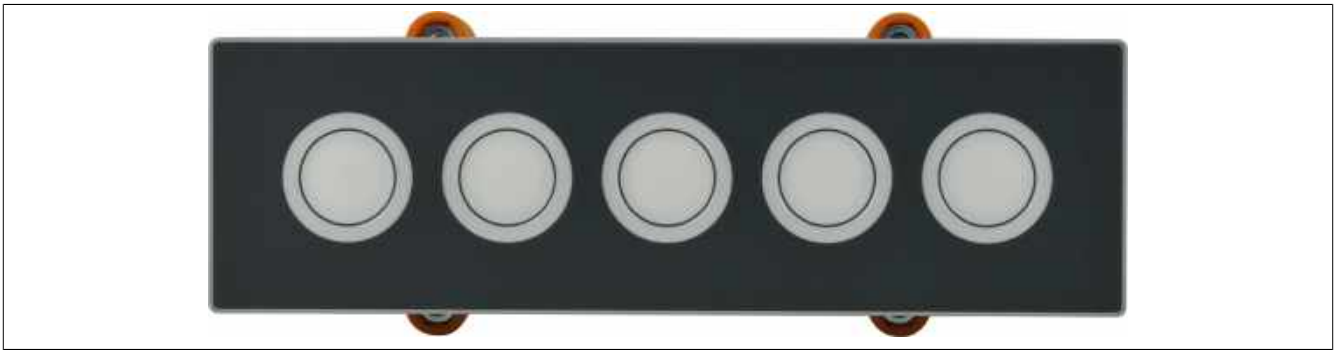

Figure 14: 4XP0057.00-00B - Front view



Figure 15: 4XP0057.00-00B - Rear view



Figure 16: 4XP0057.00-00B - Oblique view



Figure 17: 4XP0057.00-00B - Side view

3.2.1.4 Technical data

Model number	4XP0057.00-00B
General information	
LEDs	1x Run (green), 1x Error (red)
Key labels	With slide-in labels
Certifications	
CE	Yes
UL	cULus E115267 Industrial control equipment
Interfaces	
X2X	
Type	X2X slave
Variant	8-pin male multipoint connector
Internal bus power supply	Yes
Distance between 2 stations	100 m
Electrical isolation	No
Keys	
Illuminated ring keys	5x B&R illuminated ring keys (round)
Illuminated ring keys	
Color	With 4-color illumination, green, yellow, red, white (4 keys) / green, yellow, red, blue (1 key)
Service life	>1,000,000 actuations
Electrical properties	
Nominal voltage	24 VDC \pm 25%, galvanically isolated
Inrush current	Max. 20 A for <1 ms
Power consumption	Max. 0.35 A
Operating conditions	
Degree of protection per EN 60529	Front: IP65 Back: IP20
Degree of protection per UL 50	Front: Type 4X indoor use only
Ambient conditions	
Temperature	
Operation	0 to +50°C
Storage	-20 to +60°C
Transport	-20 to +60°C
Relative humidity	
Operation	T \leq 40°C: 5 to 90%, non-condensing T > 40°C: <75%, non-condensing
Storage	T \leq 40°C: 5 to 90%, non-condensing T > 40°C: <75%, non-condensing
Transport	T \leq 40°C: 5 to 90%, non-condensing T > 40°C: <75%, non-condensing
Elevation	
Operation	Max. 3000 m
Mechanical properties	
Housing	
Material	Plastic
Front	
Frame	Plastic
Panel overlay	
Material	Polyester
Design	Anthracite
Gasket	Flat gasket around display front
Dimensions	
Width	172 mm
Height	52 mm
Depth	40.4 mm
Weight	134 g

Table 6: 4XP0057.00-00B - Technical data

3.2.1.5 Panel overlay design

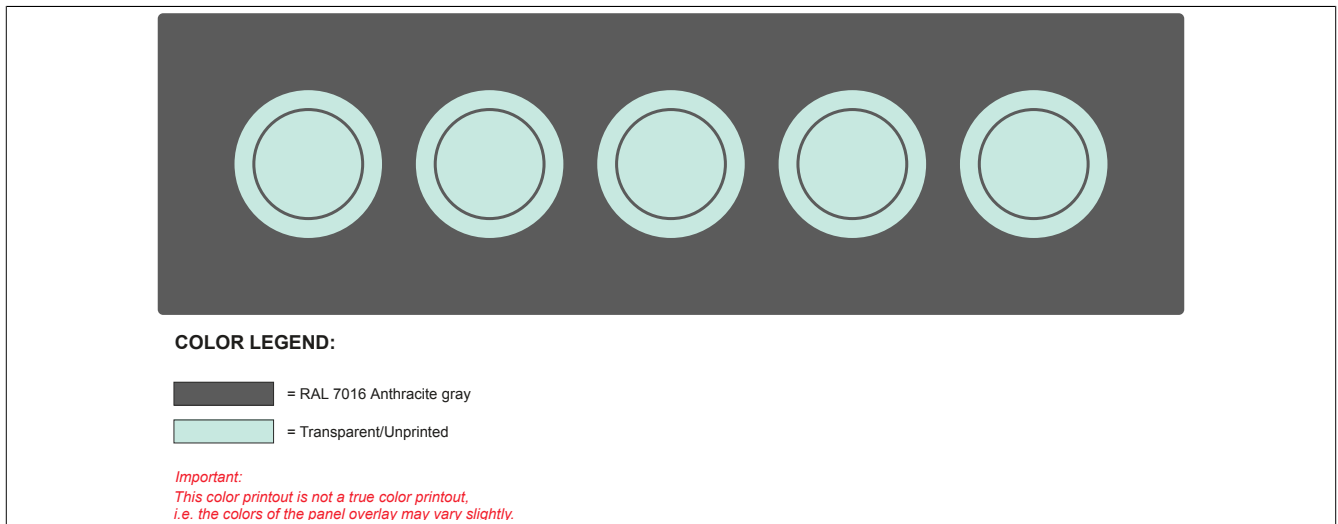

Figure 18: 4XP0057.00-00B - Panel overlay design

Information:

- To make exchanging the slide-in labels easier, it is recommended to do so before mounting the device.
- A slide-in label template can be downloaded from the B&R website (www.br-automation.com).

3.2.1.6 Adhesive device label

This adhesive label is attached to the back as a way to identify the interfaces.



Figure 19: Adhesive device label

3.2.2 4XP0057.00-00W

3.2.2.1 General

- Plastic front with inset edge protection for the panel overlay
- Panel overlay design in white aluminum
- Width to fit Power Panel T-Series / C-Series 5.7"
- IP65 protection on front, IP20 protection on back
- Fastened using retaining clips
- Keypad with 5 B&R illuminated ring keys
- All keys labeled with slide-in labels and with 4-color illumination (4x red, yellow, green, white and 1x red, yellow, green blue)
- Controlled by B&R X2X electronics, 24 VDC power supply, connected via terminal block

3.2.2.2 Order data

Model number	Short description	Figure
	Keypad modules	
4XP0057.00-00W	X2X keypad module, white aluminum, 5 B&R illuminated ring keys, with 4-color illumination: Green, yellow, red, white (4 keys) / green, yellow, red, blue (1 key), X2X interface, 24 VDC, terminal blocks included in delivery, width suitable for 5.7" Power Panel T/C	
	Included in delivery	
	Terminal blocks	
0TB6103.4100	Accessory terminal block, 3-pin (3.81), cage clamp terminal block 1.5 mm ²	
0TB6108.4100	Accessory terminal block, 8-pin (3.81), cage clamp terminal block 1.5 mm ²	

Table 7: 4XP0057.00-00W - Order data

3.2.2.3 Views - 4XP0057.00-00W

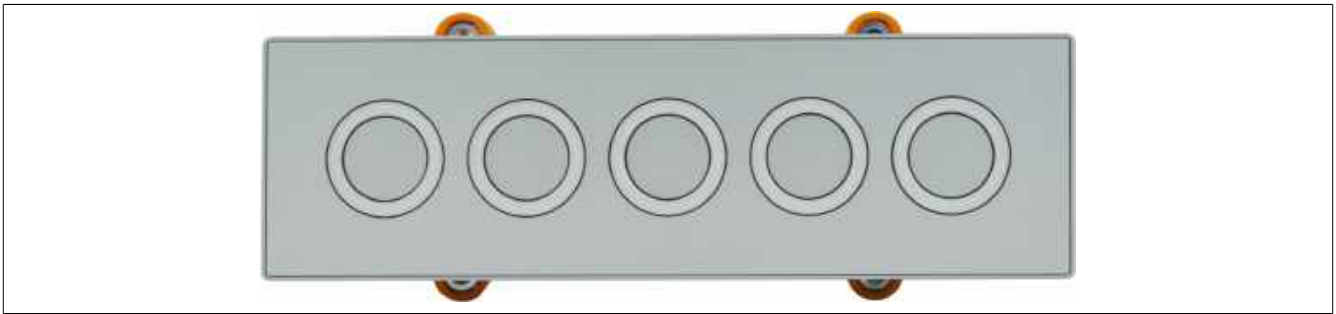

Figure 20: 4XP0057.00-00W - Front view



Figure 21: 4XP0057.00-00W - Rear view



Figure 22: 4XP0057.00-00W - Oblique view



Figure 23: 4XP0057.00-00W - Side view

3.2.2.4 Technical data

Model number	4XP0057.00-00W
General information	
LEDs	1x Run (green), 1x Error (red)
Key labels	With slide-in labels
Certifications	
CE	Yes
UL	cULus E115267 Industrial control equipment
Interfaces	
X2X	
Type	X2X slave
Variant	8-pin male multipoint connector
Internal bus power supply	Yes
Distance between 2 stations	100 m
Electrical isolation	No
Keys	
Illuminated ring keys	5x B&R illuminated ring keys (round)
Illuminated ring keys	
Color	With 4-color illumination, green, yellow, red, white (4 keys) / green, yellow, red, blue (1 key)
Service life	>1,000,000 actuations
Electrical properties	
Nominal voltage	24 VDC \pm 25%, galvanically isolated
Inrush current	Max. 20 A for <1 ms
Power consumption	Max. 0.35 A
Operating conditions	
Degree of protection per EN 60529	Front: IP65 Back: IP20
Degree of protection per UL 50	Front: Type 4X indoor use only
Ambient conditions	
Temperature	
Operation	0 to +50°C
Storage	-20 to +60°C
Transport	-20 to +60°C
Relative humidity	
Operation	T \leq 40°C: 5 to 90%, non-condensing T > 40°C: <75%, non-condensing
Storage	T \leq 40°C: 5 to 90%, non-condensing T > 40°C: <75%, non-condensing
Transport	T \leq 40°C: 5 to 90%, non-condensing T > 40°C: <75%, non-condensing
Elevation	
Operation	Max. 3000 m
Mechanical properties	
Housing	
Material	Plastic
Front	
Frame	Plastic
Panel overlay	
Material	Polyester
Design	White aluminum
Gasket	Flat gasket around display front
Dimensions	
Width	172 mm
Height	52 mm
Depth	40.4 mm
Weight	134 g

Table 8: 4XP0057.00-00W - Technical data

3.2.2.5 Panel overlay design

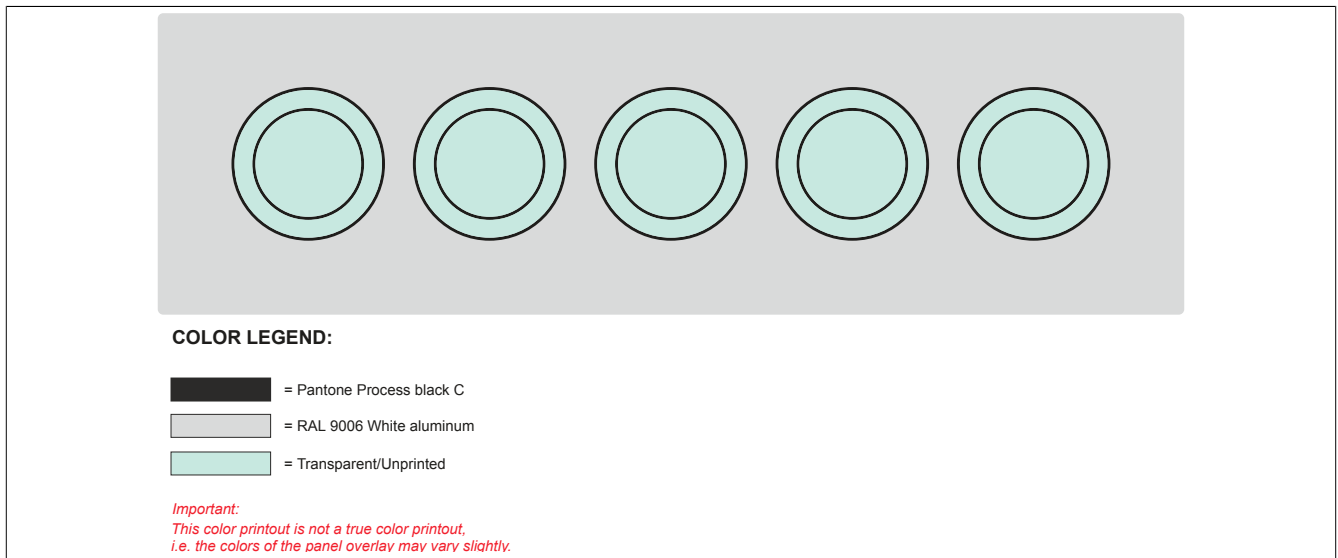

Figure 24: 4XP0057.00-00W - Panel overlay design

Information:

- To make exchanging the slide-in labels easier, it is recommended to do so before mounting the device.
- A slide-in label template can be downloaded from the B&R website (www.br-automation.com).

3.2.2.6 Adhesive device label

This adhesive label is attached to the back as a way to identify the interfaces.



Figure 25: Adhesive device label

3.2.3 4XP0057.00-00x - Dimensions

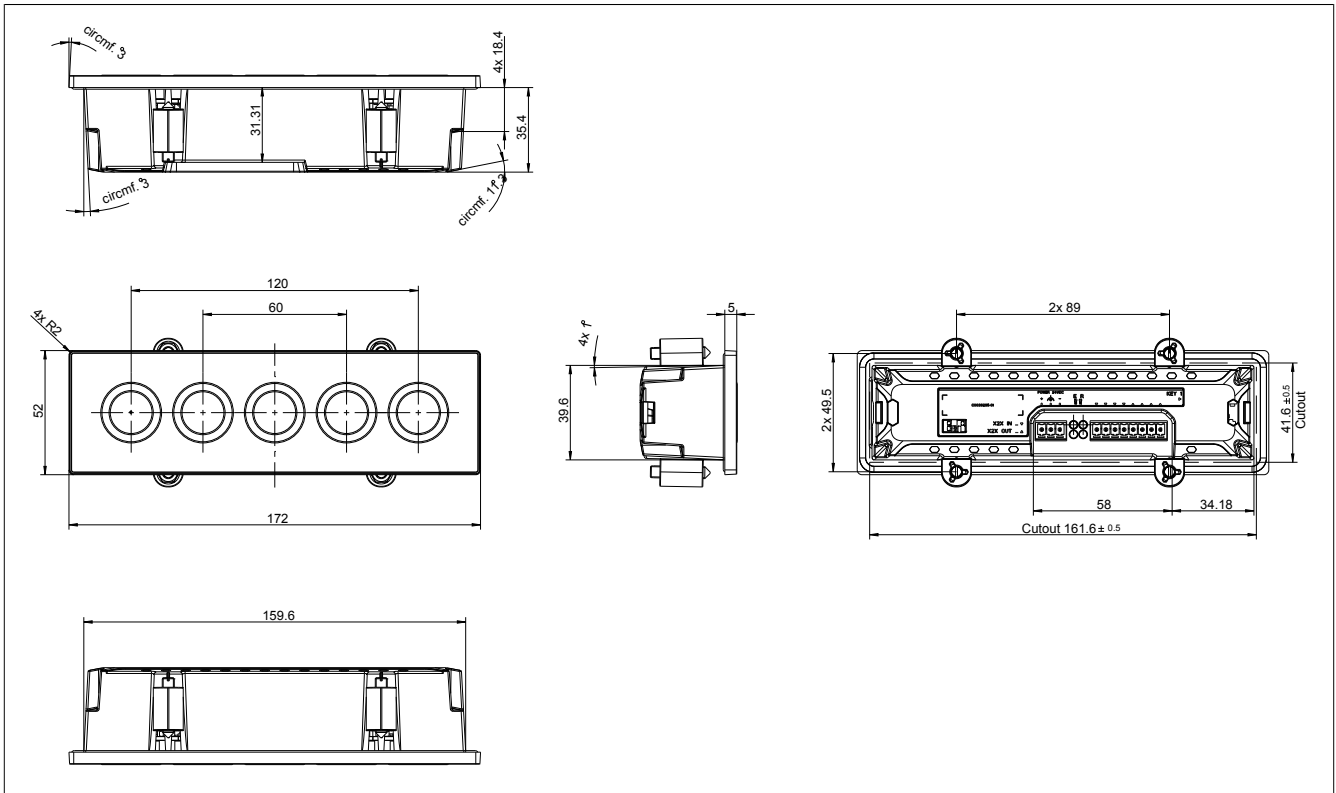

Figure 26: 4XP0057.00-00x - Dimensions

Max. control cabinet thickness: 6 mm

Cutout dimensions: 161.6 ± 0.5 mm x 41.6 ± 0.5 mm

Minimum distance between two modules: 10 mm

Notice!

- Ensure that the slide-in label does not become caught when installing the module.
- The keypad must be installed using the retaining clips included in delivery (with a maximum tightening torque of 0.4 Nm).
- IP65 protection is only provided when the surface is flush and smooth.
- The customer is responsible for providing strain relief for the cable. A slot for a cable tie is provided on both sides of the module for this purpose.

3.3 To fit Power Panel T-Series / C-Series 7"

3.3.1 4XP0070.00-00B

3.3.1.1 General

- Plastic front with inset edge protection for the panel overlay
- Panel overlay design in anthracite gray
- Width to fit Power Panel T-Series / C-Series 7"
- IP65 protection on front, IP20 protection on back
- Fastened using retaining clips
- Keypad with 5 B&R illuminated ring keys
- All keys labeled with slide-in labels and with 4-color illumination (4x red, yellow, green, white and 1x red, yellow, green blue)
- Controlled by B&R X2X electronics, 24 VDC power supply, connected via terminal block

3.3.1.2 Order data

Model number	Short description	Figure
	Keypad modules	
4XP0070.00-00B	X2X keypad module, anthracite, 5 B&R illuminated ring keys, with 4-color illumination: Green, yellow, red, white (4 keys) / green, yellow, red, blue (1 key), X2X interface, 24 VDC, terminal blocks included in delivery, width suitable for 7" Power Panel T/C	
	Included in delivery	
	Terminal blocks	
0TB6103.4100	Accessory terminal block, 3-pin (3.81), cage clamp terminal block 1.5 mm ²	
0TB6108.4100	Accessory terminal block, 8-pin (3.81), cage clamp terminal block 1.5 mm ²	

Table 9: 4XP0070.00-00B - Order data

3.3.1.3 Views - 4XP0070.00-00B



Figure 27: 4XP0070.00-00B - Front view



Figure 28: 4XP0070.00-00B - Rear view

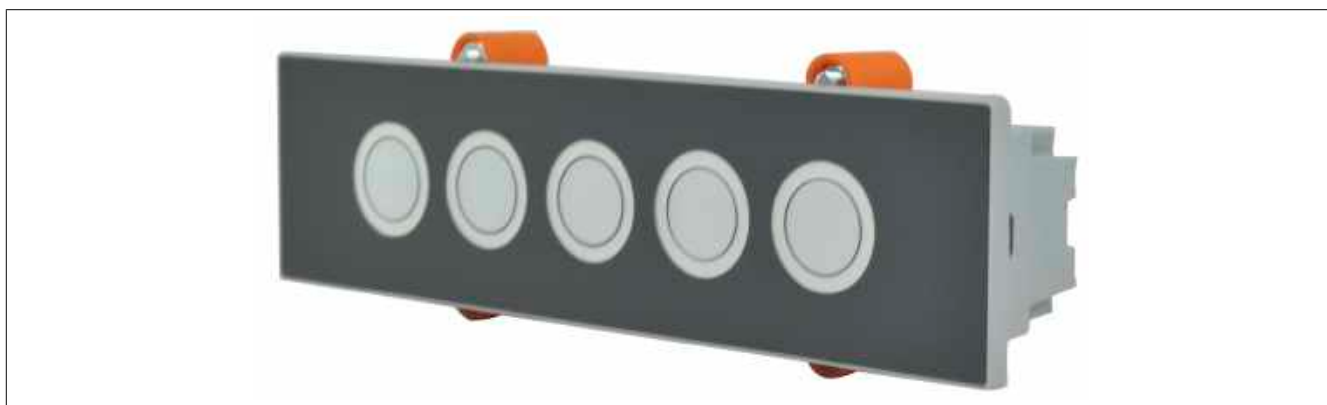

Figure 29: 4XP0070.00-00B - Oblique view



Figure 30: 4XP0070.00-00B - Side view

3.3.1.4 Technical data

Model number	4XP0070.00-00B
General information	
LEDs	1x Run (green), 1x Error (red)
Key labels	With slide-in labels
Certifications	
CE	Yes
UL	cULus E115267 Industrial control equipment
Interfaces	
X2X	
Type	X2X slave
Variant	8-pin male multipoint connector
Internal bus power supply	Yes
Distance between 2 stations	100 m
Electrical isolation	No
Keys	
Illuminated ring keys	5x B&R illuminated ring keys (round)
Illuminated ring keys	
Color	With 4-color illumination, green, yellow, red, white (4 keys) / green, yellow, red, blue (1 key)
Service life	>1,000,000 actuations
Electrical properties	
Nominal voltage	24 VDC \pm 25%, galvanically isolated
Inrush current	Max. 20 A for <1 ms
Power consumption	Max. 0.35 A
Operating conditions	
Degree of protection per EN 60529	Front: IP65 Back: IP20
Degree of protection per UL 50	Front: Type 4X indoor use only
Ambient conditions	
Temperature	
Operation	0 to +50°C
Storage	-20 to +60°C
Transport	-20 to +60°C
Relative humidity	
Operation	T \leq 40°C: 5 to 90%, non-condensing T > 40°C: <75%, non-condensing
Storage	T \leq 40°C: 5 to 90%, non-condensing T > 40°C: <75%, non-condensing
Transport	T \leq 40°C: 5 to 90%, non-condensing T > 40°C: <75%, non-condensing
Elevation	
Operation	Max. 3000 m
Mechanical properties	
Housing	
Material	Plastic
Front	
Frame	Plastic
Panel overlay	
Material	Polyester
Design	Anthracite
Gasket	Flat gasket around display front
Dimensions	
Width	197 mm
Height	52 mm
Depth	40.4 mm
Weight	147 g

Table 10: 4XP0070.00-00B - Technical data

3.3.1.5 Panel overlay design

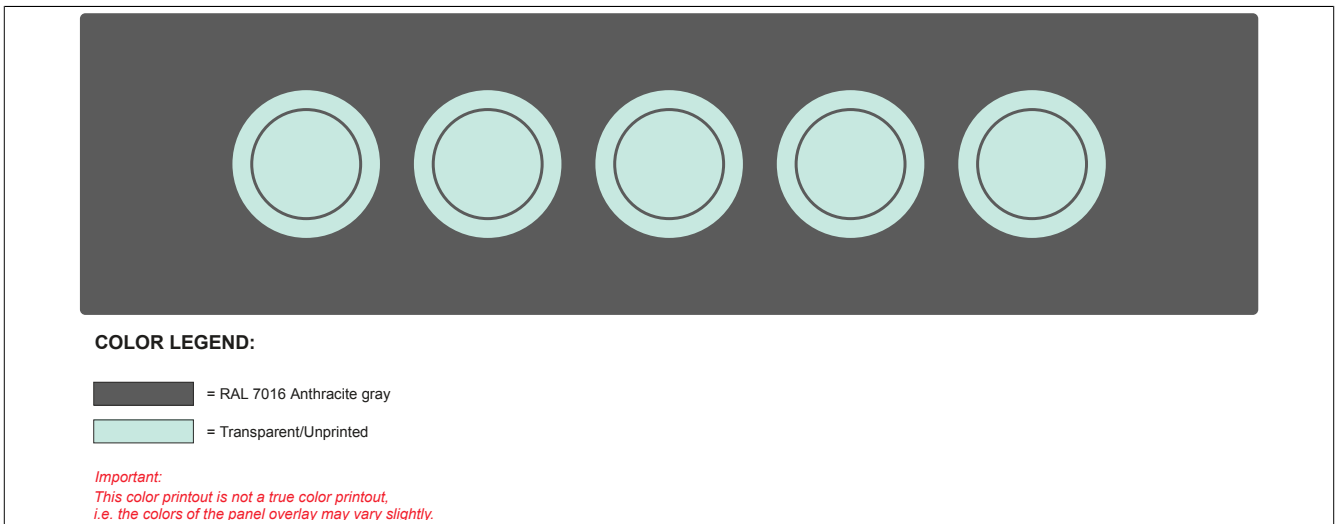

Figure 31: 4XP0070.00-00B - Panel overlay design

Information:

- To make exchanging the slide-in labels easier, it is recommended to do so before mounting the device.
- A slide-in label template can be downloaded from the B&R website (www.br-automation.com).

3.3.1.6 Adhesive device label

This adhesive label is attached to the back as a way to identify the interfaces.



Figure 32: Adhesive device label

3.3.2 4XP0070.00-00W

3.3.2.1 General

- Plastic front with inset edge protection for the panel overlay
- Panel overlay design in white aluminum
- Width to fit Power Panel T-Series / C-Series 7"
- IP65 protection on front, IP20 protection on back
- Fastened using retaining clips
- Keypad with 5 B&R illuminated ring keys
- All keys labeled with slide-in labels and with 4-color illumination (4x red, yellow, green, white and 1x red, yellow, green blue)
- Controlled by B&R X2X electronics, 24 VDC power supply, connected via terminal block

3.3.2.2 Order data

Model number	Short description	Figure
	Keypad modules	
4XP0070.00-00W	X2X keypad module, white aluminum, 5 B&R illuminated ring keys, with 4-color illumination: Green, yellow, red, white (4 keys) / green, yellow, red, blue (1 key), X2X interface, 24 VDC, terminal blocks included in delivery, width suitable for 7" Power Panel T/C	
	Included in delivery	
	Terminal blocks	
0TB6103.4100	Accessory terminal block, 3-pin (3.81), cage clamp terminal block 1.5 mm ²	
0TB6108.4100	Accessory terminal block, 8-pin (3.81), cage clamp terminal block 1.5 mm ²	

Table 11: 4XP0070.00-00W - Order data

3.3.2.3 Views - 4XP0070.00-00W

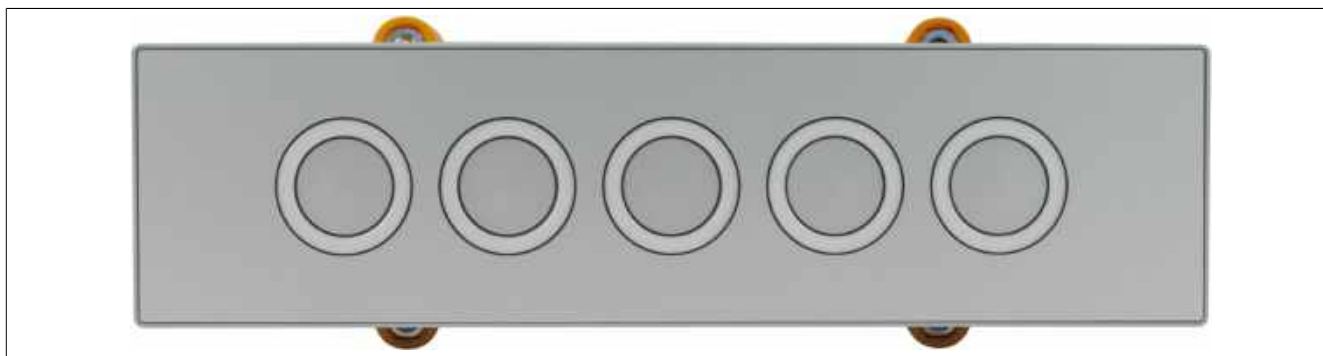

Figure 33: 4XP0070.00-00W - Front view



Figure 34: 4XP0070.00-00W - Rear view



Figure 35: 4XP0070.00-00W - Oblique view



Figure 36: 4XP0070.00-00W - Side view

3.3.2.4 Technical data

Model number	4XP0070.00-00W
General information	
LEDs	1x Run (green), 1x Error (red)
Key labels	With slide-in labels
Certifications	
CE	Yes
UL	cULus E115267 Industrial control equipment
Interfaces	
X2X	
Type	X2X slave
Variant	8-pin male multipoint connector
Internal bus power supply	Yes
Distance between 2 stations	100 m
Electrical isolation	No
Keys	
Illuminated ring keys	5x B&R illuminated ring keys (round)
Illuminated ring keys	
Color	With 4-color illumination, green, yellow, red, white (4 keys) / green, yellow, red, blue (1 key)
Service life	>1,000,000 actuations
Electrical properties	
Nominal voltage	24 VDC \pm 25%, galvanically isolated
Inrush current	Max. 20 A for <1 ms
Power consumption	Max. 0.35 A
Operating conditions	
Degree of protection per EN 60529	Front: IP65 Back: IP20
Degree of protection per UL 50	Front: Type 4X indoor use only
Ambient conditions	
Temperature	
Operation	0 to +50°C
Storage	-20 to +60°C
Transport	-20 to +60°C
Relative humidity	
Operation	T \leq 40°C: 5 to 90%, non-condensing T > 40°C: <75%, non-condensing
Storage	T \leq 40°C: 5 to 90%, non-condensing T > 40°C: <75%, non-condensing
Transport	T \leq 40°C: 5 to 90%, non-condensing T > 40°C: <75%, non-condensing
Elevation	
Operation	Max. 3000 m
Mechanical properties	
Housing	
Material	Plastic
Front	
Frame	Plastic
Panel overlay	
Material	Polyester
Design	White aluminum
Gasket	Flat gasket around display front
Dimensions	
Width	197 mm
Height	52 mm
Depth	40.4 mm
Weight	147 g

Table 12: 4XP0070.00-00W - Technical data

3.3.2.5 Panel overlay design

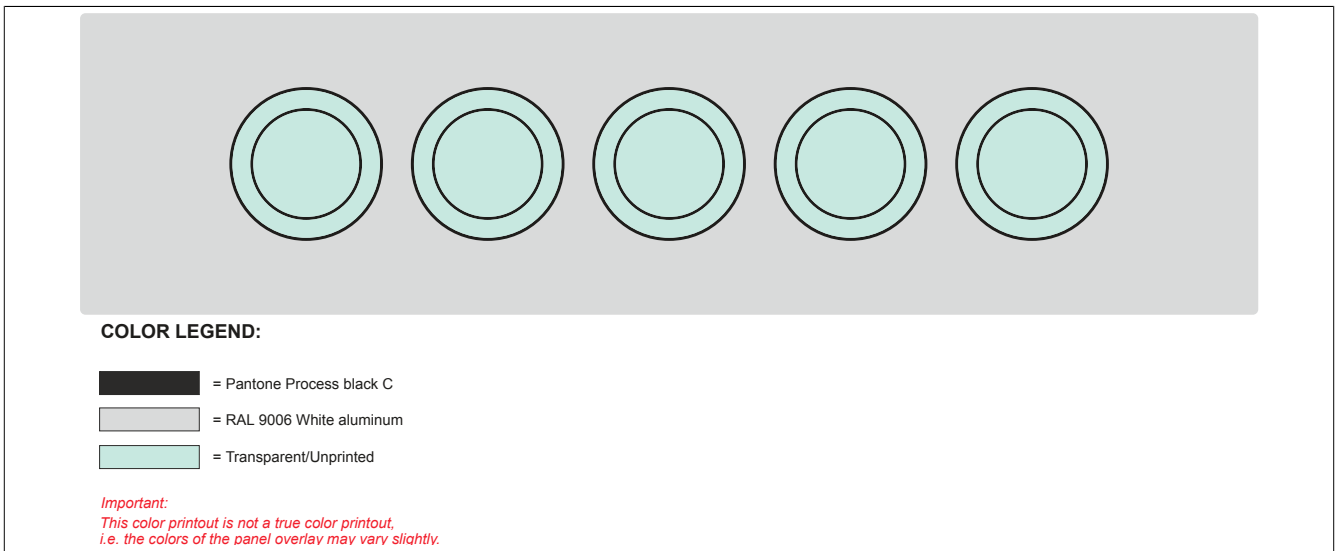

Figure 37: 4XP0070.00-00W - Panel overlay design

Information:

- To make exchanging the slide-in labels easier, it is recommended to do so before mounting the device.
- A slide-in label template can be downloaded from the B&R website (www.br-automation.com).

3.3.2.6 Adhesive device label

This adhesive label is attached to the back as a way to identify the interfaces.



Figure 38: Adhesive device label

3.3.3 4XP0070.00-00x - Dimensions

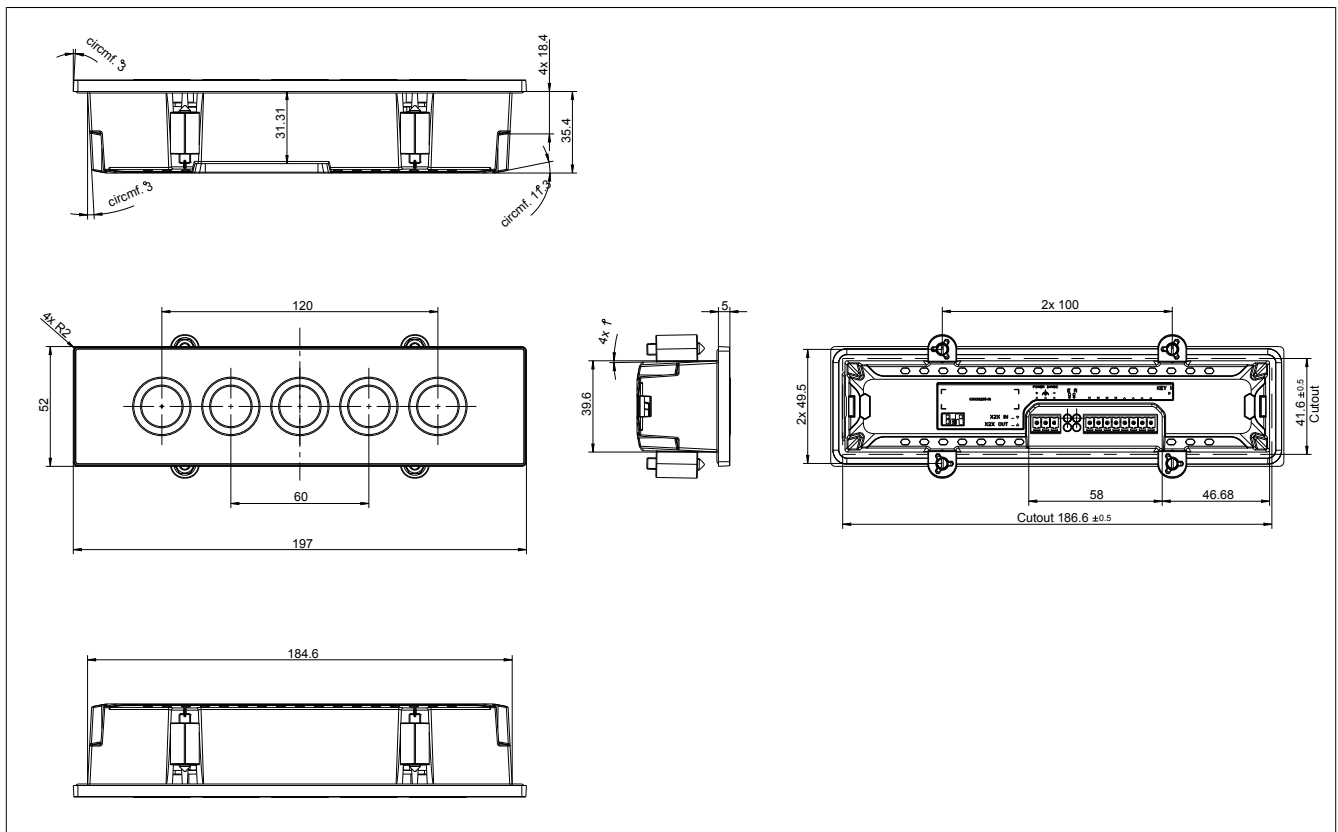

Figure 39: 4XP0070.00-00x - Dimensions

Max. control cabinet thickness: 6 mm

Cutout dimensions: 186.6 ± 0.5 mm x 41.6 ± 0.5 mm

Minimum distance between two modules: 10 mm

Notice!

- Ensure that the slide-in label does not become caught when installing the module.
- The keypad must be installed using the retaining clips included in delivery (with a maximum tightening torque of 0.4 Nm).
- IP65 protection is only provided when the surface is flush and smooth.
- The customer is responsible for providing strain relief for the cable. A slot for a cable tie is provided on both sides of the module for this purpose.

3.4 To fit Power Panel T-Series / C-Series 10.1"

3.4.1 4XP0101.00-00B

3.4.1.1 General

- Plastic front with inset edge protection for the panel overlay
- Panel overlay design in anthracite gray
- Width to fit Power Panel T-Series / C-Series 10.1"
- IP65 protection on front, IP20 protection on back
- Fastened using retaining clips
- Keypad with 8 B&R illuminated ring keys
- All keys labeled with slide-in labels and with 4-color illumination (7x red, yellow, green, white and 1x red, yellow, green blue)
- Controlled by B&R X2X electronics, 24 VDC power supply, connected via terminal block

3.4.1.2 Order data

Model number	Short description	Figure
	Keypad modules	
4XP0101.00-00B	X2X keypad module, anthracite, 8 B&R illuminated ring keys, with 4-color illumination: Green, yellow, red, white (7 keys) / green, yellow, red, blue (1 key), X2X interface, 24 VDC, terminal blocks included in delivery, width suitable for 10.1" Power Panel T/C	
	Included in delivery	
	Terminal blocks	
0TB6103.4100	Accessory terminal block, 3-pin (3.81), cage clamp terminal block 1.5 mm ²	
0TB6108.4100	Accessory terminal block, 8-pin (3.81), cage clamp terminal block 1.5 mm ²	

Table 13: 4XP0101.00-00B - Order data

3.4.1.3 Views - 4XP0101.00-00B



Figure 40: 4XP0101.00-00B - Front view



Figure 41: 4XP0101.00-00B - Rear view



Figure 42: 4XP0101.00-00B - Oblique view



Figure 43: 4XP0101.00-00B - Side view

3.4.1.4 Technical data

Model number	4XP0101.00-00B
General information	
LEDs	1x Run (green), 1x Error (red)
Key labels	With slide-in labels
Certifications	
CE	Yes
UL	cULus E115267 Industrial control equipment
Interfaces	
X2X	
Type	X2X slave
Variant	8-pin male multipoint connector
Internal bus power supply	Yes
Distance between 2 stations	100 m
Electrical isolation	No
Keys	
Illuminated ring keys	8x B&R illuminated ring keys (round)
Illuminated ring keys	
Color	With 4-color illumination, green, yellow, red, white (7 keys) / green, yellow, red, blue (1 key)
Service life	>1,000,000 actuations
Electrical properties	
Nominal voltage	24 VDC \pm 25%, galvanically isolated
Inrush current	Max. 20 A for <1 ms
Power consumption	Max. 0.35 A
Operating conditions	
Degree of protection per EN 60529	Front: IP65 Back: IP20
Degree of protection per UL 50	Front: Type 4X indoor use only
Ambient conditions	
Temperature	
Operation	0 to +50°C
Storage	-20 to +60°C
Transport	-20 to +60°C
Relative humidity	
Operation	T \leq 40°C: 5 to 90%, non-condensing T > 40°C: <75%, non-condensing
Storage	T \leq 40°C: 5 to 90%, non-condensing T > 40°C: <75%, non-condensing
Transport	T \leq 40°C: 5 to 90%, non-condensing T > 40°C: <75%, non-condensing
Elevation	
Operation	Max. 3000 m
Mechanical properties	
Housing	
Material	Plastic
Front	
Frame	Plastic
Panel overlay	
Material	Polyester
Design	Anthracite
Gasket	Flat gasket around display front
Dimensions	
Width	276 mm
Height	52 mm
Depth	40.4 mm
Weight	200 g

Table 14: 4XP0101.00-00B - Technical data

3.4.1.5 Panel overlay design

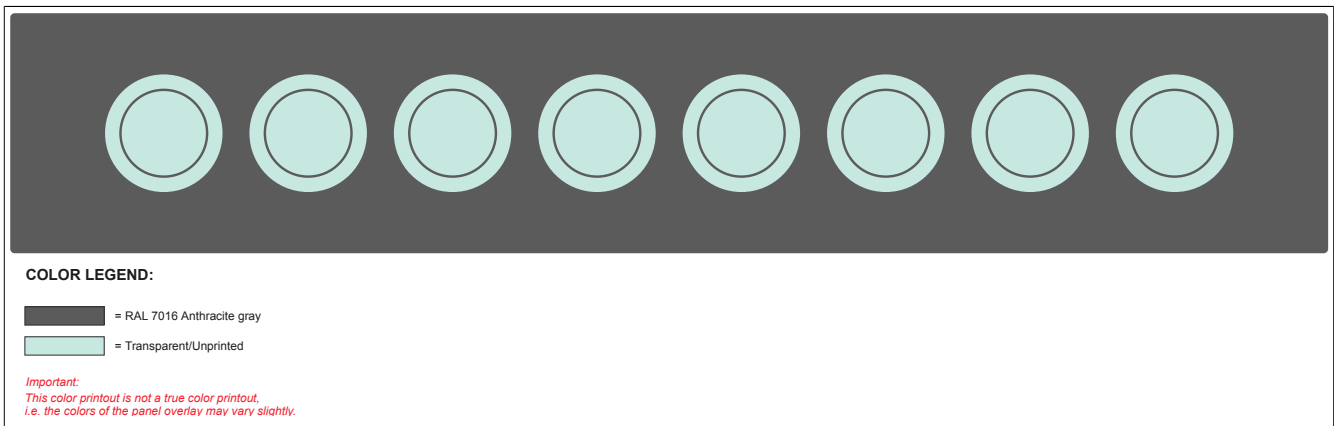

Figure 44: 4XP0101.00-00B - Panel overlay design

Information:

- To make exchanging the slide-in labels easier, it is recommended to do so before mounting the device.
- A slide-in label template can be downloaded from the B&R website (www.br-automation.com).

3.4.1.6 Adhesive device label

This adhesive label is attached to the back as a way to identify the interfaces.



Figure 45: Adhesive device label

3.4.2 4XP0101.00-00W

3.4.2.1 General

- Plastic front with inset edge protection for the panel overlay
- Panel overlay design in white aluminum
- Width to fit Power Panel T-Series / C-Series 10.1"
- IP65 protection on front, IP20 protection on back
- Fastened using retaining clips
- Keypad with 8 B&R illuminated ring keys
- All keys labeled with slide-in labels and with 4-color illumination (7x red, yellow, green, white and 1x red, yellow, green blue)
- Controlled by B&R X2X electronics, 24 VDC power supply, connected via terminal block

3.4.2.2 Order data

Model number	Short description	Figure
	Keypad modules	
4XP0101.00-00W	X2X keypad module, white aluminum, 8 B&R illuminated ring keys, with 4-color illumination: Green, yellow, red, white (7 keys) / green, yellow, red, blue (1 key), X2X interface, 24 VDC, terminal blocks included in delivery, width suitable for 10.1" Power Panel T/C	
	Included in delivery	
	Terminal blocks	
0TB6103.4100	Accessory terminal block, 3-pin (3.81), cage clamp terminal block 1.5 mm ²	
0TB6108.4100	Accessory terminal block, 8-pin (3.81), cage clamp terminal block 1.5 mm ²	

Table 15: 4XP0101.00-00W - Order data

3.4.2.3 Views - 4XP0101.00-00W

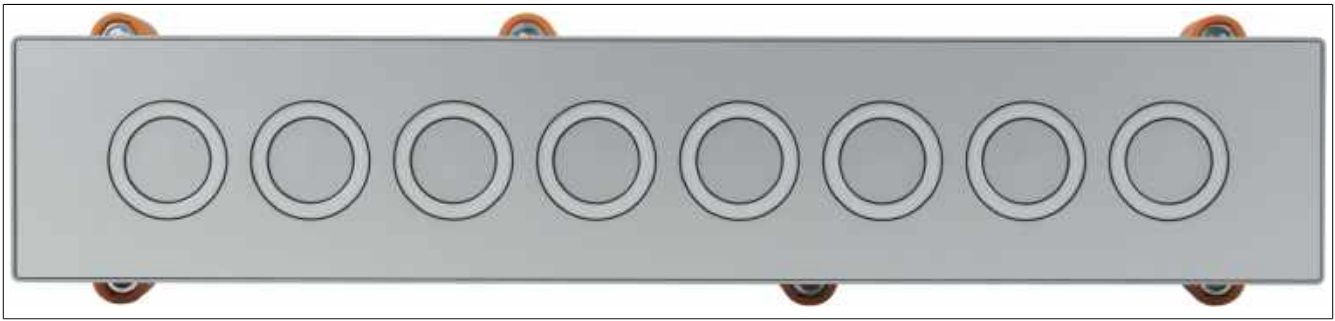

Figure 46: 4XP0101.00-00W - Front view



Figure 47: 4XP0101.00-00W - Rear view

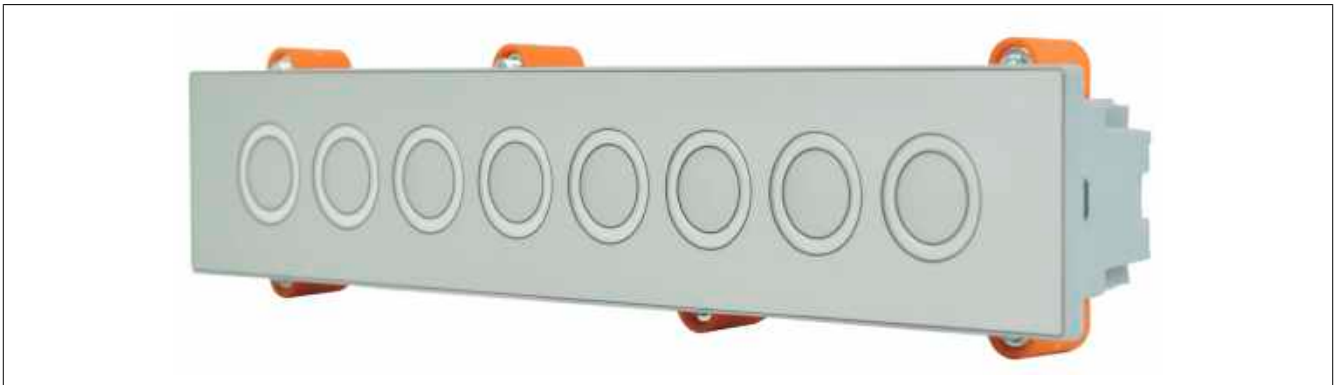

Figure 48: 4XP0101.00-00W - Oblique view



Figure 49: 4XP0101.00-00W - Side view

3.4.2.4 Technical data

Model number	4XP0101.00-00W
General information	
LEDs	1x Run (green), 1x Error (red)
Key labels	With slide-in labels
Certifications	
CE	Yes
UL	cULus E115267 Industrial control equipment
Interfaces	
X2X	
Type	X2X slave
Variant	8-pin male multipoint connector
Internal bus power supply	Yes
Distance between 2 stations	100 m
Electrical isolation	No
Keys	
Illuminated ring keys	8x B&R illuminated ring keys (round)
Illuminated ring keys	
Color	With 4-color illumination, green, yellow, red, white (7 keys) / green, yellow, red, blue (1 key)
Service life	>1,000,000 actuations
Electrical properties	
Nominal voltage	24 VDC \pm 25%, galvanically isolated
Inrush current	Max. 20 A for <1 ms
Power consumption	Max. 0.35 A
Operating conditions	
Degree of protection per EN 60529	Front: IP65 Back: IP20
Degree of protection per UL 50	Front: Type 4X indoor use only
Ambient conditions	
Temperature	
Operation	0 to +50°C
Storage	-20 to +60°C
Transport	-20 to +60°C
Relative humidity	
Operation	T \leq 40°C: 5 to 90%, non-condensing T > 40°C: <75%, non-condensing
Storage	T \leq 40°C: 5 to 90%, non-condensing T > 40°C: <75%, non-condensing
Transport	T \leq 40°C: 5 to 90%, non-condensing T > 40°C: <75%, non-condensing
Elevation	
Operation	Max. 3000 m
Mechanical properties	
Housing	
Material	Plastic
Front	
Frame	Plastic
Panel overlay	
Material	Polyester
Design	White aluminum
Gasket	Flat gasket around display front
Dimensions	
Width	276 mm
Height	52 mm
Depth	40.4 mm
Weight	200 g

Table 16: 4XP0101.00-00W - Technical data

3.4.2.5 Panel overlay design

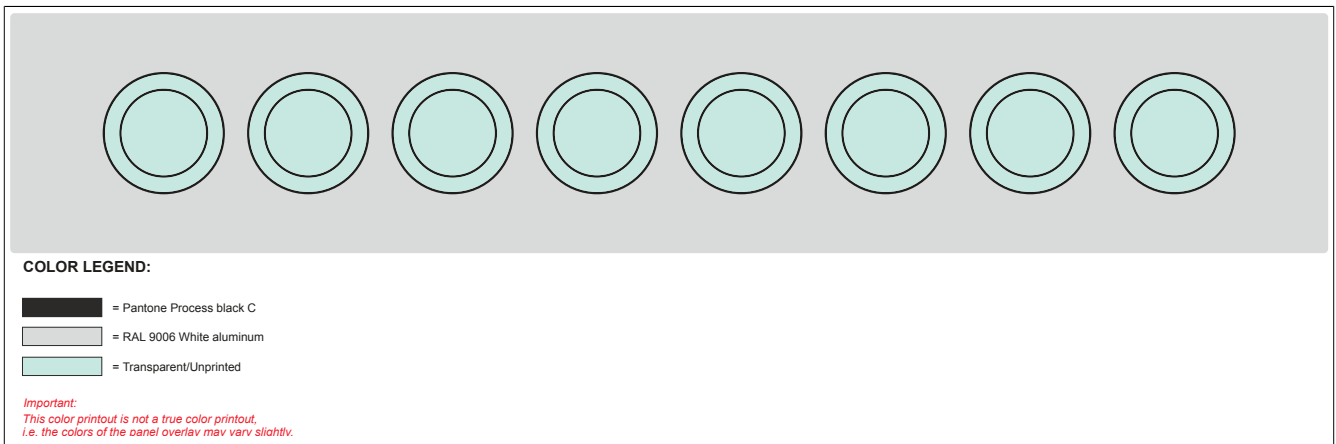

Figure 50: 4XP0101.00-00W - Panel overlay design

Information:

- To make exchanging the slide-in labels easier, it is recommended to do so before mounting the device.
- A slide-in label template can be downloaded from the B&R website (www.br-automation.com).

3.4.2.6 Adhesive device label

This adhesive label is attached to the back as a way to identify the interfaces.



Figure 51: Adhesive device label

3.4.3 4XP0101.00-00x - Dimensions

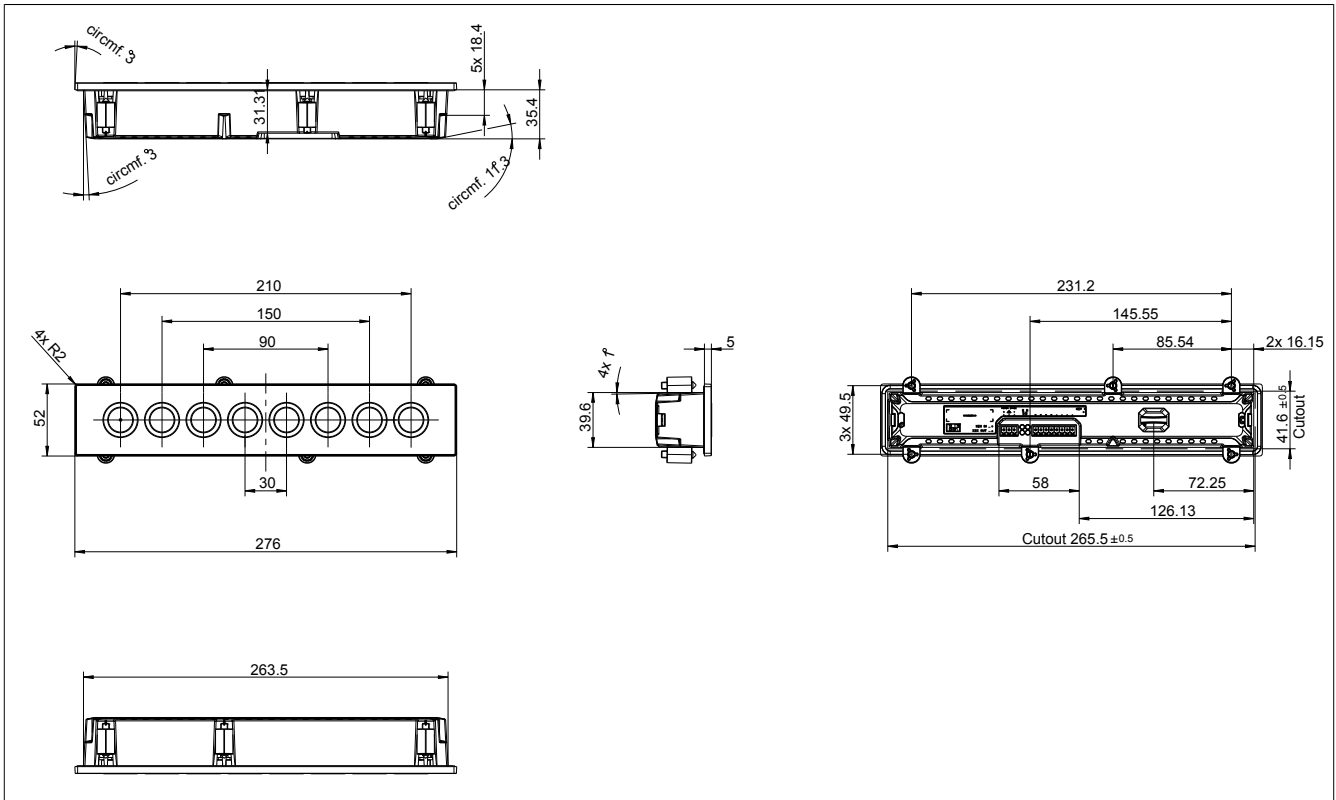

Figure 52: 4XP0101.00-00x - Dimensions

Max. control cabinet thickness: 6 mm

Cutout dimensions: 265.6 ± 0.5 mm x 41.6 ± 0.5 mm

Minimum distance between two modules: 10 mm

Notice!

- Ensure that the slide-in label does not become caught when installing the module.
- The keypad must be installed using the retaining clips included in delivery (with a maximum tightening torque of 0.4 Nm).
- IP65 protection is only provided when the surface is flush and smooth.
- The customer is responsible for providing strain relief for the cable. A slot for a cable tie is provided on both sides of the module for this purpose.

4 Features - Technical data

4.1 +24 VDC power supply

Danger!

The device is only permitted to be supplied with a SELV/PELV power supply or with safety extra-low voltage (SELV) per EN 60950.

Input voltage: 24 VDC \pm 25%

For the pinout, see the following table or adhesive label. The power supply is internally protected so that the device is not damaged if the supply voltage is overloaded or incorrectly connected.

The 3-pin male connector necessary for connecting the power supply is included in delivery. It can also be ordered from B&R using the order number below.

The power supply must be provided with a wire cross section of at least 1 mm².

Power supply		3-pin, male
Pin	Description	
Reverse polarity protection		
1	-	
2	Functional ground	
3	+	
Accessories		
0TB6103.4100	Accessory 3-pin cage clamp terminal block (3.81)	

Table 17: 24 VDC power supply connection

4.2 X2X interface

The panel is equipped with one X2X Link interface. The interface is galvanically isolated and connected to an 8-pin multipoint connector.

The 8-pin male connector necessary for the connection is included in delivery. It can also be ordered from B&R using the model number below.

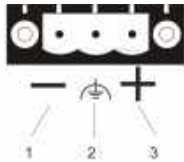
X2X interface			
Connection	Description		
1	SHLD	X2X OUT	
2	X2X \		
3	X2X ⊥		
4	X2X		
5	SHLD	X2X IN	
6	X2X \		
7	X2X ⊥		
8	X2X		
Accessories			
0TB6108.4100	Accessory 8-pin cage clamp terminal block (3.81)		

Table 18: X2X interface

4.3 LED status indicator

LED status indicator		
LED	Color	Description
Run	Green	Connection to X2X bus established
Error	Red	No connection to X2X bus possible
		

Table 19: LED status indicator

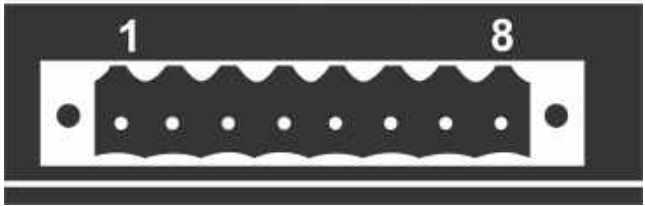
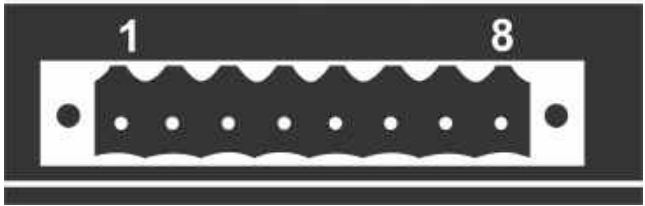
5 Key and LED configurations

Each key and LED can be individually configured and adapted to the application. The following B&R tools are available for this purpose:

Visual Components for Automation Runtime

The following graphics show the positions of the keys and LEDs in the matrix. They are represented as follows.

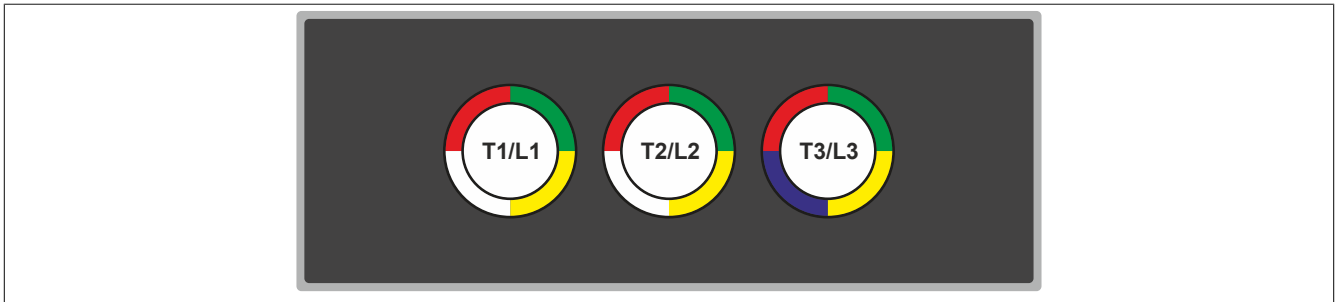

Figure 53: 4XP0043.00-00B - Hardware numbers

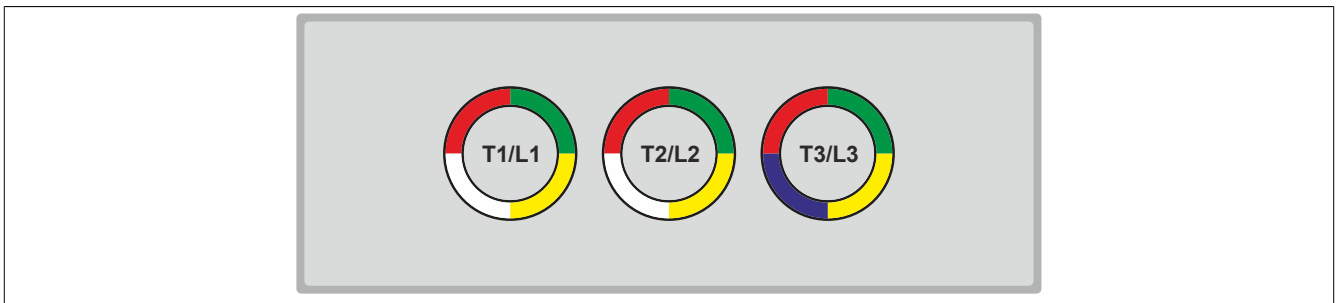

Figure 54: 4XP0043.00-00W - Hardware numbers

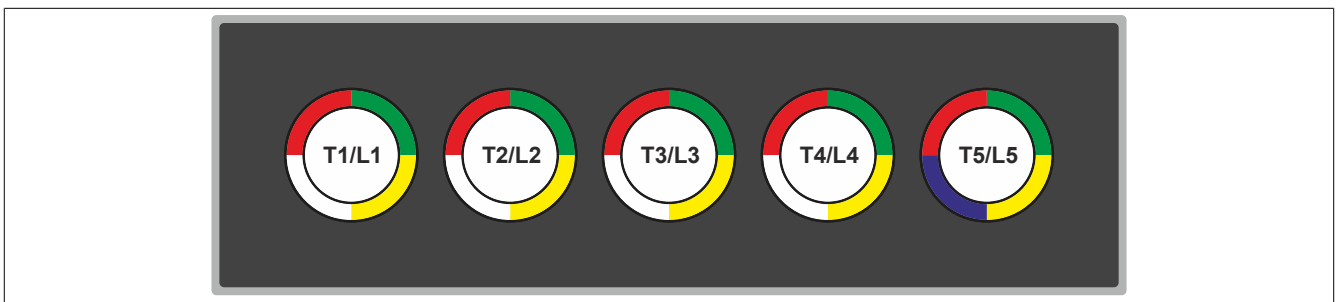

Figure 55: 4XP0057.00-00B - Hardware numbers

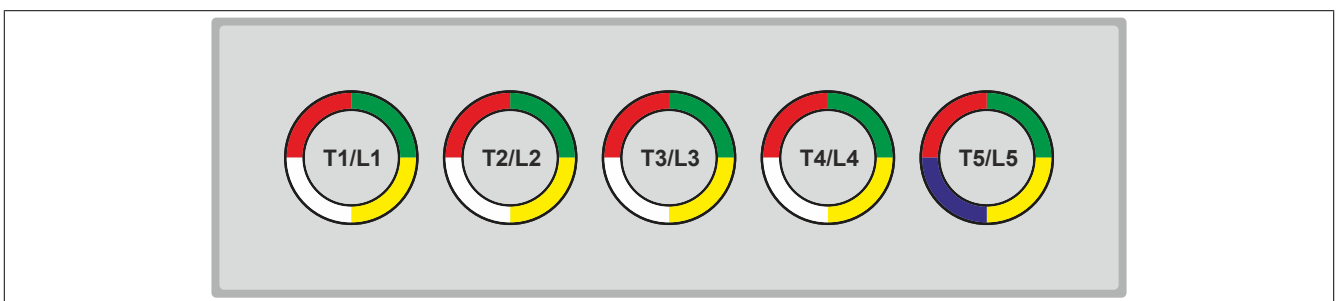

Figure 56: 4XP0057.00-00W - Hardware numbers

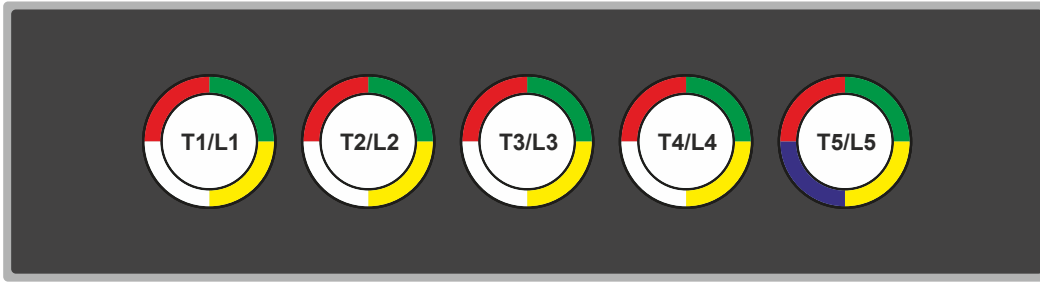

Figure 57: 4XP0070.00-00B - Hardware numbers

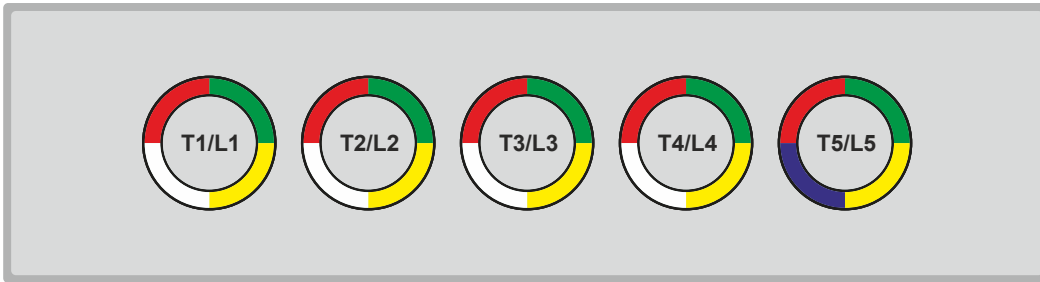

Figure 58: 4XP0057.00-00W - Hardware numbers

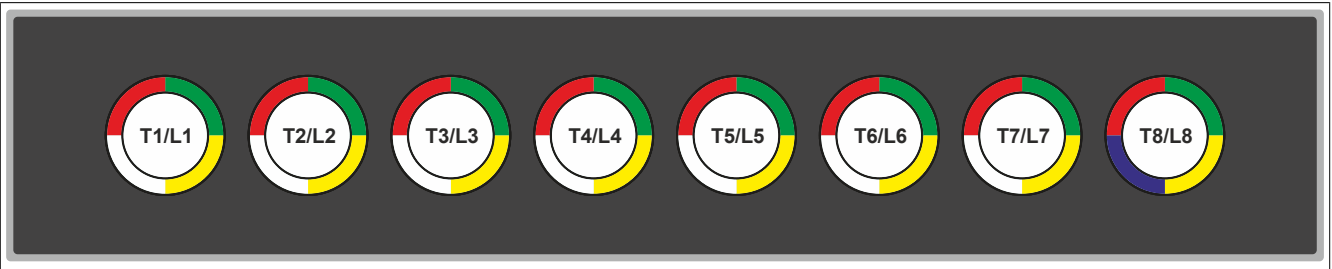

Figure 59: 4XP0101.00-00B - Hardware numbers

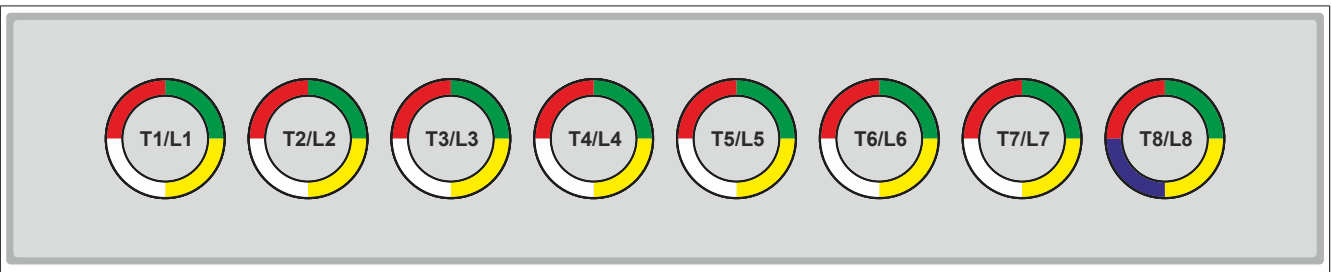

Figure 60: 4XP0101.00-00W - Hardware numbers

6 Cleaning

Danger!

In order to prevent unintentional operation (by touching the touch screen or keys), the device is only permitted to be cleaned when the power is switched off.

- Use a cloth moistened with dishwashing detergent, screen cleaner or alcohol (ethanol) to clean the device.
- The cleaning agent is not permitted to be applied directly to the device.
Abrasive cleaners, aggressive solvents and chemicals, compressed air or steam cleaners are not permitted to be used.

6.1 Surface resistance of the panel overlay

The panel overlay conforms to DIN 42115 (Part 2). This means it is resistant to exposure to the following chemicals for a 24-hour period with no visible signs of damage:

Ethanol Cyclohexanol Diacetone alcohol Glycol Isopropanol Glycerine Methanol Triacetin Dowandol DRM/PM	Formaldehyde 37%-42% Acetaldehyde Aliphatic hydrocarbons Toluene Xylene White spirits	Trichloroethane Ethyl acetate Diethyl ether n-Butyl acetate Amyl acetate Butylcellosolve Ether
Acetone Methyl ethyl ketone Dioxan Cyclohexanone Methylisobutylketone (MIBK) Isophorone	Formic acid < 50% Acetic acid < 50% Phosphoric acid < 30% Hydrochloric acid < 36% Nitric acid < 10% Trichloroacetic acid < 50% Sulphuric acid < 10%	Sodium chloride <20% Hydrogen peroxide < 25% Potassium carbonate Washing agents Tenside Fabric conditioner Iron (II) chloride Iron (III) chloride Dibutyl phthalate Diocetyl phthalate Sodium carbonate
Ammonia < 40% Caustic soda < 40% Potassium hydroxide Alkali carbonate Bichromate Potassium Acetonitrile Sodium bisulphate	Cutting oil Diesel oil Linseed oil Paraffin oil Ricinus oil Silicon oil Turpentine oil substitute Brake fluid Aviation fuel Gasoline Water Sea water Decon	

Information:

The specified characteristics, features and limit values only apply to this individual component and can deviate from those specified for the complete system.

Per DIN 42115 Part 2, the panel overlay is resistant to glacial acetic acid for less than one hour without visible damage.

7 EC declaration of conformity

This document was originally written in the German language. The German edition therefore represents the original documentation in accordance with the 2006/42/EC Machinery Directive. Documents in other languages should be interpreted as translations of the original documentation.

Product manufacturer:

B&R Industrial Automation GmbH

B&R Strasse 1

5142 Eggelsberg

Austria

Telephone: +43 7748 6586-0

Fax: +43 7748 6586-26

office@br-automation.com

The place of jurisdiction, in accordance with article 17 of the European Convention on Courts of Jurisdiction and Enforcement, is A-4910

Ried im Innkreis, Austria, commercial register court: Ried im Innkreis, Austria

Commercial register number: FN 111651 v.

The place of fulfillment in accordance with article 5 of the European Convention on Courts of Jurisdiction and Enforcement is A-5142 Eggelsberg, Austria

VATIN: ATU62367156

The EC declarations of conformity for B&R products can be downloaded from the B&R website www.br-automation.com.

Publishing information

B&R Industrial Automation GmbH

B&R Strasse 1

5142 Eggelsberg

Austria

Telephone: +43 7748 6586-0

Fax: +43 7748 6586-26

office@br-automation.com