

SDL4/DVI Converter

User's manual

Version: **1.12 (April 2020)**
Order no.: **MASDL4DVI-ENG**

Translation of the original documentation

All values in this manual are current as of its creation. We reserve the right to change the contents of this manual without notice. B&R Industrial Automation GmbH is not liable for technical or editorial errors and defects in this manual. In addition, B&R Industrial Automation GmbH assumes no liability for damages that are directly or indirectly attributable to the delivery, performance or use of this material. We point out that the software and hardware designations and brand names of the respective companies used in this document are subject to general trademark, brand or patent protection.

1 Introduction.....	4
1.1 Manual history.....	4
1.2 Information about this document.....	4
1.2.1 Organization of notices.....	4
1.2.2 Guidelines.....	4
2 General safety guidelines.....	5
2.1 Intended use.....	5
2.2 Protection against electrostatic discharge.....	5
2.2.1 Packaging.....	5
2.2.2 Regulations for proper ESD handling.....	5
2.3 Regulations and measures.....	5
2.4 Transport and storage.....	6
2.5 Installation.....	6
2.6 Operation.....	6
2.6.1 Protection against contact with electrical parts.....	6
2.6.2 Ambient conditions - Dust, moisture, aggressive gases.....	6
2.6.3 Programs, viruses and malicious programs.....	7
2.7 Cybersecurity disclaimer for products.....	7
3 System overview.....	8
3.1 Information about this user's manual.....	8
3.2 SDL4/DVI Converter for Automation PCs.....	8
3.3 Connection options.....	9
3.3.1 SDL4-DVI connection option.....	9
3.3.2 General limitations/characteristics.....	10
3.3.2.1 USB endpoint analysis.....	10
3.4 Design/Configuration.....	11
3.5 System data.....	12
3.5.1 5COSD4.1002-00.....	12
3.5.1.1 General information.....	12
3.5.1.2 Order data.....	12
3.5.1.3 Technical data.....	13
3.5.1.4 Dimensions.....	14
3.5.2 Device interfaces and slots.....	15
3.5.2.1 Device interfaces - Overview.....	15
3.6 Overview.....	19
4 Dimensioning.....	20
4.1 Spacing for air circulation.....	20
5 Installation and wiring.....	21
5.1 Basic information.....	21
5.2 Installing the SDL4/DVI Converter.....	23
5.2.1 Procedure.....	23
5.3 Installing the cable strain relief clip.....	24
5.4 Connecting to the power grid.....	25
5.4.1 Installing the DC power cable.....	25
5.4.1.1 Wiring.....	25
5.4.2 Connecting the power supply to a B&R device.....	25
5.4.3 Grounding concept.....	27
5.5 Connecting cables.....	28
5.6 Removing the SDL4/DVI Converter.....	29
5.6.1 Procedure.....	29

6 Commissioning	30
6.1 Basic information.....	30
6.2 Switching on the device for the first time.....	30
6.2.1 General information before switching on the device.....	30
6.2.2 Switching on the SDL4/DVI Converter.....	30
7 Software	31
7.1 Updates.....	31
8 Maintenance	32
8.1 Repairs/Complaints and replacement parts.....	32
9 International and national certifications	33
9.1 Directives and declarations.....	33
9.1.1 CE marking.....	33
9.1.2 EMC Directive.....	33
9.2 Certifications.....	34
9.2.1 UL certification.....	34
9.2.2 EAC.....	34
10 Accessories	35
10.1 General accessories.....	35
10.1.1 Accessories - Order data.....	35
10.2 OTB103.9x.....	36
10.2.1 General information.....	36
10.2.2 Order data.....	36
10.2.3 Technical data.....	36
10.3 Cables.....	37
10.3.1 SDL3/SDL4 cables.....	37
10.3.1.1 5CASD3.xxxx-00.....	37
10.3.2 DVI cables.....	40
10.3.2.1 5CADVI.0xxx-00.....	40
10.4 Cable strain relief clip.....	43
10.4.1 5ACCRHMI.0012-000.....	43
10.4.1.1 General information.....	43
10.4.1.2 Order data.....	43
10.4.1.3 Technical data.....	43
11 Environmentally friendly disposal	44
11.1 Separation of materials.....	44

1 Introduction

1.1 Manual history

Version	Date	Change
1.00	June 2019	• First version
1.05	July 2019	• Updated "+24 VDC power supply" on page 15.
1.10	September 2019	• Updated temperature specifications in "Technical data" on page 13 and "USB interfaces" on page 18.
1.11	January 2020	• Updated temperature specifications in "Technical data" on page 13 and "USB interfaces" on page 18; updated weight specifications.
1.12	April 2020	• Updated temperature specifications in "Technical data" on page 13 and "USB interfaces" on page 18.

1.2 Information about this document

This document is not intended for end customers! The safety guidelines required for end customers must be incorporated into the operating instructions for end customers in the respective national language by the machine manufacturer or system provider.

1.2.1 Organization of notices

Safety notices

Contain **only** information that warns of dangerous functions or situations.

Signal word	Description
Danger!	Failure to observe these safety guidelines and notices will result in death, severe injury or substantial damage to property.
Warning!	Failure to observe these safety guidelines and notices can result in death, severe injury or substantial damage to property.
Caution!	Failure to observe these safety guidelines and notices can result in minor injury or damage to property.
Notice!	Failure to observe these safety guidelines and notices can result in damage to property.

General notices

Contain **useful** information for users and instructions for avoiding malfunctions.

Signal word	Description
Information:	Useful information, application tips and instructions for avoiding malfunctions.

1.2.2 Guidelines

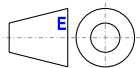

European dimension standards apply to all dimension diagrams.

All dimensions in mm.

Unless otherwise specified, the following general tolerances apply:

Nominal dimension range	General tolerance per DIN ISO 2768 medium
Up to 6 mm	±0.1 mm
Over 6 to 30 mm	±0.2 mm
Over 30 to 120 mm	±0.3 mm
Over 120 to 400 mm	±0.5 mm
Over 400 to 1000 mm	±0.8 mm

2 General safety guidelines

2.1 Intended use

Programmable logic controllers, operating and monitoring devices (e.g. industrial PCs, Power Panels, Mobile Panels) as well as uninterruptible power supplies from B&R have been designed, developed and manufactured for normal use in industry. They have not been designed, developed and manufactured for use that involves fatal risks or hazards that could result in death, injury, serious physical harm or other loss without the assurance of exceptionally stringent safety precautions. In particular, this includes the use of these systems to monitor nuclear reactions in nuclear power plants, flight control systems, air traffic control, the control of mass transport vehicles, medical life support systems and the control of weapon systems.

2.2 Protection against electrostatic discharge

Electrical assemblies that can be damaged by electrostatic discharge (ESD) must be handled accordingly.

2.2.1 Packaging

- **Electrical assemblies with housing:**
Do not require special ESD packaging but must be handled properly (see "Electrical assemblies with housing").
- **Electrical assemblies without housing:**
Are protected by ESD-suitable packaging.

2.2.2 Regulations for proper ESD handling

Electrical assemblies with housing

- Do not touch the connector contacts of connected cables.
- Do not touch the contact tips on circuit boards.

Electrical assemblies without housing

The following applies in addition to "Electrical assemblies with housing":

- All persons handling electrical assemblies and devices in which electrical assemblies are installed must be grounded.
- Assemblies are only permitted to be touched on the narrow sides or front plate.
- Always place assemblies on suitable surfaces (ESD packaging, conductive foam, etc.). Metallic surfaces are not suitable surfaces!
- Assemblies must not be subjected to electrostatic discharges (e.g. due to charged plastics).
- A minimum distance of 10 cm from monitors or television sets must be maintained.
- Measuring instruments and devices must be grounded.
- Test probes of floating potential measuring instruments must be discharged briefly on suitable grounded surfaces before measurement.

Individual components

- ESD protective measures for individual components are implemented throughout B&R (conductive floors, shoes, wrist straps, etc.).
- The increased ESD protective measures for individual components are not required for handling B&R products at customer locations.

2.3 Regulations and measures

Electronic devices are generally not failsafe. If the programmable logic controller, operating or control device or uninterruptible power supply fails, the user is responsible for ensuring that connected devices (such as motors) are brought to a safe state.

General safety guidelines

When using programmable logic controllers as well as when using operating and monitoring devices as control systems in conjunction with a Soft PLC (e.g. B&R Automation Runtime or similar product) or Slot PLC (e.g. B&R LS251 or similar product), the safety measures that apply to industrial controllers (protection by protective equipment such as emergency stops) must be observed in accordance with applicable national and international regulations. This also applies to all other connected devices, such as drives.

All work such as installation, commissioning and servicing are only permitted to be carried out by qualified personnel. Qualified personnel are persons who are familiar with the transport, installation, assembly, commissioning and operation of the product and have the appropriate qualifications for their job (e.g. IEC 60364). National accident prevention regulations must be observed.

The safety guidelines, information about connection conditions (nameplate and documentation) and limit values specified in the technical data must be read carefully before installation and commissioning and must be strictly observed.

2.4 Transport and storage

During transport and storage, devices must be protected against undue stress (mechanical stress, temperature, humidity, aggressive atmosphere).

2.5 Installation

- The devices are not ready for use and must be installed and wired according to the requirements of this documentation in order to comply with EMC limit values.
- Installation must be carried out according to the documentation using suitable equipment and tools.
- Devices are only permitted to be installed by qualified personnel when the power is switched off. The control cabinet must first be disconnected from the power supply and secured against being switched on again.
- General safety regulations and national accident prevention regulations must be observed.
- The electrical installation must be carried out in accordance with relevant regulations (e.g. wire cross section, fuse protection, protective ground connection).

2.6 Operation

2.6.1 Protection against contact with electrical parts

In order to operate programmable logic controllers, operating and monitoring devices and uninterruptible power supplies, it is necessary for certain components to carry dangerous voltages over 42 VDC. Touching one of these components can result in a life-threatening electric shock. There is a risk of death, serious injury or damage to property.

Before switching on programmable logic controllers, operating and monitoring devices and uninterruptible power supplies, it must be ensured that the housing is properly connected to ground potential (PE rail). The ground connection must also be made if the operating and monitoring device and uninterruptible power supply are only connected for testing purposes or only operated for a short time!

Before switching on, live parts must be securely covered. All covers must be kept closed during operation.

2.6.2 Ambient conditions - Dust, moisture, aggressive gases

The use of operating and monitoring devices (e.g. industrial PCs, Power Panels, Mobile Panels) and uninterruptible power supplies in dusty environments must be avoided. This can otherwise result in dust deposits that affect the functionality of the device, especially in systems with active cooling (fans), which may no longer ensure sufficient cooling.

The presence of aggressive gases in the environment can also result in malfunctions. In combination with high temperature and relative humidity, aggressive gases – for example with sulfur, nitrogen and chlorine components – trigger chemical processes that can very quickly impair or damage electronic components. Blackened copper surfaces and cable ends in existing installations are indicators of aggressive gases.

When operated in rooms with dust and condensation that can endanger functionality, operating and monitoring devices such as Automation Panels or Power Panels are protected on the front against the ingress of dust and moisture when installed correctly (e.g. cutout installation). The back of all devices must be protected against the ingress of dust and moisture, however, or the dust deposits must be removed at suitable intervals.

2.6.3 Programs, viruses and malicious programs

Any data exchange or installation of software using data storage media (e.g. floppy disk, CD-ROM, USB flash drive) or via networks or the Internet poses a potential threat to the system. It is the direct responsibility of the user to avert these dangers and to take appropriate measures such as virus protection programs and firewalls to protect against them and to use only software from trustworthy sources.

2.7 Cybersecurity disclaimer for products

B&R products communicate via a network interface and were developed for secure connection with internal and, if necessary, other networks such as the Internet.

Information:

In the following, B&R products are referred to as "product" and all types of networks (e.g. internal networks and the Internet) are referred to as "network".

It is the sole responsibility of the customer to establish and continuously ensure a secure connection between the product and the network. In addition, appropriate security measures must be implemented and maintained to protect the product and entire network from any security breaches, unauthorized access, interference, digital intrusion, data leakage and/or theft of data or information.

B&R Industrial Automation GmbH and its subsidiaries are not liable for damages and/or losses in connection with security breaches, unauthorized access, malfunctions, digital intrusion, data leakage and/or theft of data or information.

The aforementioned appropriate security measures include, for example:

- Segmentation of the network (e.g. separation of the IT network from the control network¹⁾)
- Use of firewalls
- Use of authentication mechanisms
- Encryption of data
- Use of anti-malware software

Before B&R releases products or updates, they are subjected to appropriate functional testing. Independently of this, we recommend that our customers develop their own test processes in order to be able to check the effects of changes in advance. Such changes include, for example:

- Installation of product updates
- Significant system modifications such as configuration changes
- Deployment of updates or patches for third-party software (non-B&R software)
- Hardware replacement

These tests should ensure that implemented security measures remain effective and that systems in the customer's environment behave as expected.

¹⁾ The term "control network" refers to computer networks used to connect control systems. The control network can be divided into zones, and there can be several separate control networks within a company or site. The term "control systems" refers to all types of B&R products such as controllers (e.g. X20), HMI systems (e.g. Power Panel T30), process control systems (e.g. APROL) and supporting systems such as engineering workstations with Automation Studio.

3 System overview

3.1 Information about this user's manual

This user's manual contains all necessary information about the SDL4/DVI Converter. For information about B&R industrial PCs, see the respective user's manuals.

Information:

All specifications in dimension diagrams and associated tables are in millimeters [mm].

3.2 SDL4/DVI Converter for Automation PCs

The SDL4/DVI Converter makes operation via SDL4 with Automation PCs possible for monitors and panels that are only equipped with a DVI interface. This makes it easy to upgrade systems to SDL4 as part of retrofit measures and conversions.



3.3 Connection options

3.3.1 SDL4-DVI connection option

With the SDL4/DVI Converter, monitors and panels that are only equipped with a DVI interface can also be connected to a B&R industrial PC with SDL4 even over long distances.

Various USB devices can be connected to the 3 available USB interfaces (e.g. keyboard, mouse).

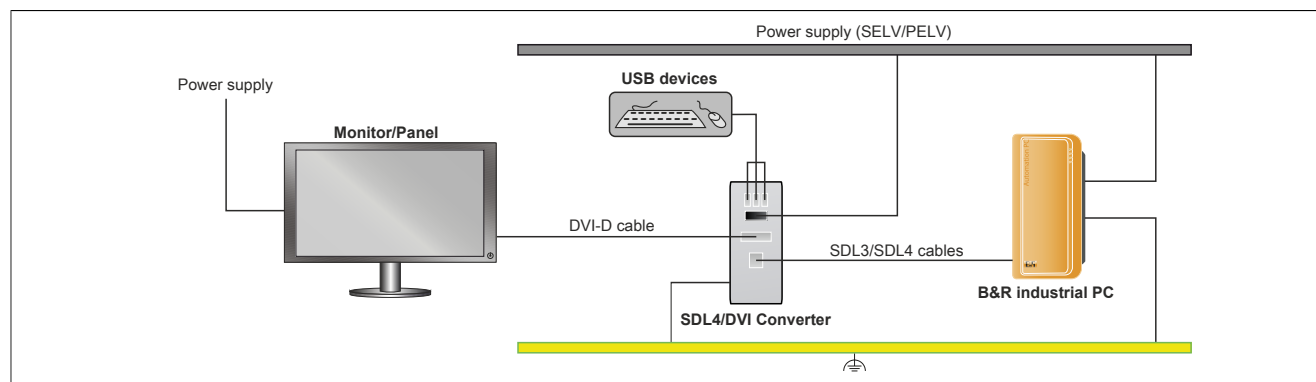

Maximum cable length for SDL4: 100 m

Maximum cable length for DVI and USB: 5 m

Necessary components:

- Monitor or panel with DVI interface
- B&R industrial PC with SDL4 interface
- SDL4/DVI Converter
- DVI-D cable, SDL3/SDL4 cable

Optional components:

- USB devices and USB cables

Limitations

- Service and diagnostic data is not transferred.
- Data transfer is limited to the DVI specification (single link). If SDL panels are connected, they can only be used as DVI display units.

3.3.2 General limitations/characteristics

- USB 2.0 transfer is limited to 150 Mbit/s with SDL4.
- If multiple USB devices are connected to the panel, it is important to note that only a certain number of USB endpoints are available. If this number is exceeded, communication problems with the USB devices may occur. This property is explained in detail below.

3.3.2.1 USB endpoint analysis

It is possible to analyze the number and type of endpoints on a particular USB device. Third-party USB analysis tools can be used for this purpose.

The SDL4 connection has a limited number of USB IN and USB OUT endpoints. This can cause problems if multiple USB devices are connected at the same time.

Endpoints

Devices must be distinguished from *endpoints*:

A device can be considered a USB peripheral that connects to a host, such as a mouse, keyboard, camera, flash drive or mass storage device such as a hard disk.

Endpoints can be considered as data sources or storage locations, i.e. buffers that cache data during a transaction.

This means that a USB device can have multiple endpoints. There is no direct relation between the number of endpoints and the number of devices supported by a USB port.

Devices

SDL4 technology currently supports up to seven USB devices. Hubs are not counted since they are transparent (not visible) from the user's perspective. They are not considered as a device, nor are they counted in relation to endpoints.

The limitation concerning the maximum number of connected devices or maximum number of endpoints applies as soon as one of the maximum values is reached. For example, if all endpoints are assigned (i.e. allocated) by connecting two devices, no more devices are permitted to be connected (although the maximum of seven devices has not yet been reached).

Hubs

SDL4 currently supports up to eight downstream ports per hub. This means that it is possible to identify all eight ports on a given hub. By comparison, if SDL4 supported only four ports per hub, ports five to eight – on an eight-port hub – would be switched off and therefore unusable.





If more than one hub is connected (e.g. if several hubs are linked together), the limit of eight ports per hub remains.

Determining the maximum available endpoints

A certain number of endpoints is available depending on the transfer rate of the devices used.

Transfer rate of the devices	Endpoints	
	IN	OUT
High speed	11	12
Full speed / Low speed	12	12

3.4 Design/Configuration

Configuration					
SDL4/DVI Converter					Select 1
	5COSD4.1002-00 (SDL4/DVI)				
SDL3/SDL4/PoE cables					Select 1
	5CASD3.0030-00 5CASD3.0200-00	5CASD3.0050-00 5CASD3.0300-00	5CASD3.0100-00 5CASD3.0500-00	5CASD3.0150-00 5CASD3.1000-00	
DVI cables					Select 1
	5CADVI.0018-00		5CADVI.0050-00		
Terminal blocks					Select 1
	Power supply connector				
	0TB103.9		0TB103.91		
Accessories					Optional selection
	Cable strain relief clip				
	5ACCRHMI.0012-000				

3.5 System data

3.5.1 5COSD4.1002-00

3.5.1.1 General information

The SDL4/DVI Converter makes operation via SDL4 with Automation PCs possible for monitors and panels that are only equipped with a DVI interface. This makes it easy to upgrade systems to SDL4 as part of retrofit measures and conversions.

3.5.1.2 Order data

Model number	Short description	Figure
	Converter	
5COSD4.1002-00	SDL4/DVI Converter	
	Required accessories	
	Accessories	
0TB103.9	Connector 24 VDC - 3-pin, female - Screw clamp terminal block 3.31 mm ²	
0TB103.91	Connector 24 VDC - 3-pin, female - Cage clamp terminal block 3.31 mm ²	
	SDL3/SDL4/PoE cables	
5CASD3.0030-00	SDL3/SDL4/FT50 cable - 3 m - FT50 including Power over Ethernet	
5CASD3.0050-00	SDL3/SDL4/FT50 cable - 5 m - FT50 including Power over Ethernet	
5CASD3.0100-00	SDL3/SDL4/FT50 cable - 10 m - FT50 including Power over Ethernet	
5CASD3.0150-00	SDL3/SDL4/FT50 cable - 15 m - FT50 including Power over Ethernet	
5CASD3.0200-00	SDL3/SDL4/FT50 cable - 20 m - FT50 including Power over Ethernet	
5CASD3.0300-00	SDL3/SDL4/FT50 cable - 30 m - FT50 including Power over Ethernet	
5CASD3.0500-00	SDL3/SDL4/FT50 cable - 50 m - FT50 including Power over Ethernet	
5CASD3.1000-00	SDL3/SDL4 cable - 100 m	
	Optional accessories	
	Accessories	
5ACCRHMI.0000-000	REP HMI grounding clip	
5ACCRHMI.0012-000	REP strain relief USB - For SDL4/DVI Converter	
	DVI cables	
5CADVI.0018-00	DVI-D cable - 1.8 m	
5CADVI.0050-00	DVI-D cable - 5 m	

Table 1: 5COSD4.1002-00 - Order data

3.5.1.3 Technical data

Information:

The following specified characteristic data, features and limit values are only valid for these individual components and may differ from those of the complete system. The data specified for the complete system applies to the complete system in which this individual component is used, for example.

Model number	5COSD4.1002-00
General information	
LEDs	Power, SDL4 In, DVI Out
B&R ID code	0xF4EA
Certifications	
CE	Yes
UL	cULus E115267 Industrial control equipment
Interfaces	
USB	
Quantity	3
Type	USB 2.0
Variant	Type A
Transfer rate	Low speed (1.5 Mbit/s), full speed (12 Mbit/s) to high speed (480 Mbit/s)
DVI interface	
Quantity	1
Variant	DVI-I
Type	DVI-D (single link)
SDL4 In	
Quantity	1
Variant	Female RJ45 connector, shielded
Type	SDL4
Electrical properties	
Nominal voltage	24 VDC \pm 25%, SELV ¹⁾
Nominal current	Max. 0.5 A
Overvoltage category per EN 61131-2	II
Galvanic isolation	Yes
Operating conditions	
Pollution degree per EN 61131-2	Pollution degree 2
Degree of protection per EN 60529	IP20
Ambient conditions	
Temperature	
Operation	0 to 55°C ²⁾³⁾
Storage	-20 to 60°C
Transport	-20 to 60°C
Relative humidity	
Operation	5 to 90%, non-condensing
Storage	5 to 95%, non-condensing
Transport	5 to 95%, non-condensing
Vibration ⁴⁾	
Operation (continuous)	2 to 9 Hz: 1.75 mm amplitude / 9 to 200 Hz: 0.5 g peak
Operation (occasional)	2 to 9 Hz: 3.5 mm amplitude / 9 to 200 Hz: 1 g peak
Storage	2 to 8 Hz: 7.5 mm amplitude / 8 to 200 Hz: 2 g peak / 200 to 500 Hz: 4 g peak
Transport	2 to 8 Hz: 7.5 mm amplitude / 8 to 200 Hz: 2 g peak / 200 to 500 Hz: 4 g peak
Shock ⁴⁾	
Operation	15 g peak, 11 ms
Storage	30 g peak, 6 ms
Transport	30 g peak, 6 ms
Elevation	
Operation	Max. 3000 m ²⁾
Mechanical properties	
Housing	
Material	Aluminum
Coating	White
Dimensions	
Width	40 mm
Height	100 mm
Depth	80 mm
Weight	Approx. 420 g

Table 2: 5COSD4.1002-00 - Technical data

- 1) EN 60950 requirements must be observed.
- 2) The temperature specifications correspond to a specification at 500 meters. The max. ambient temperature is typically derated 1°C per 1000 meters starting at 500 m above sea level.
- 3) Depends on the total power of the connected USB devices, see section "USB interfaces".
- 4) Top-hat rail clamp set X20AC0RF1 can also be used for improved installation / vibration resistance.
Vibration testing is performed per EN 60068-2-6. Shock testing is performed per EN 60068-2-27.

3.5.1.4 Dimensions

Information:

All specifications in dimension diagrams and associated tables are in millimeters [mm].

2D and 3D diagrams (DXF and STEP formats) can be downloaded from the B&R website (www.br-automation.com).

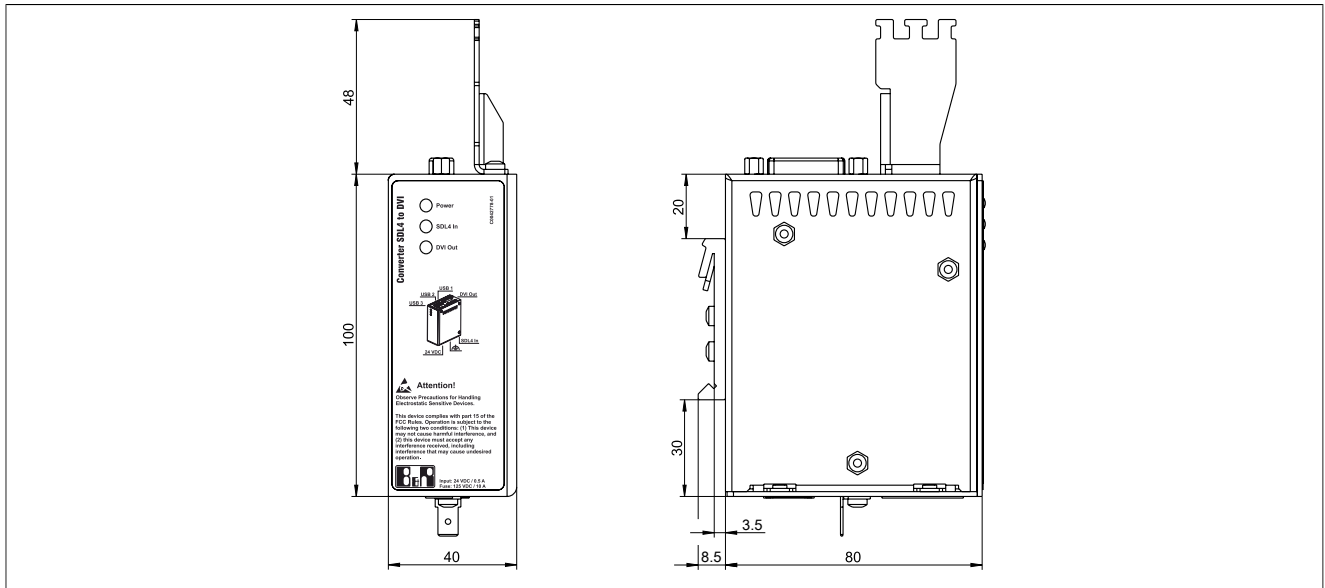

3.5.2 Device interfaces and slots

3.5.2.1 Device interfaces - Overview

Information:

The interfaces available on the device or module are numbered for the purpose of clear differentiation. The numbering used by the operating system may deviate, however.

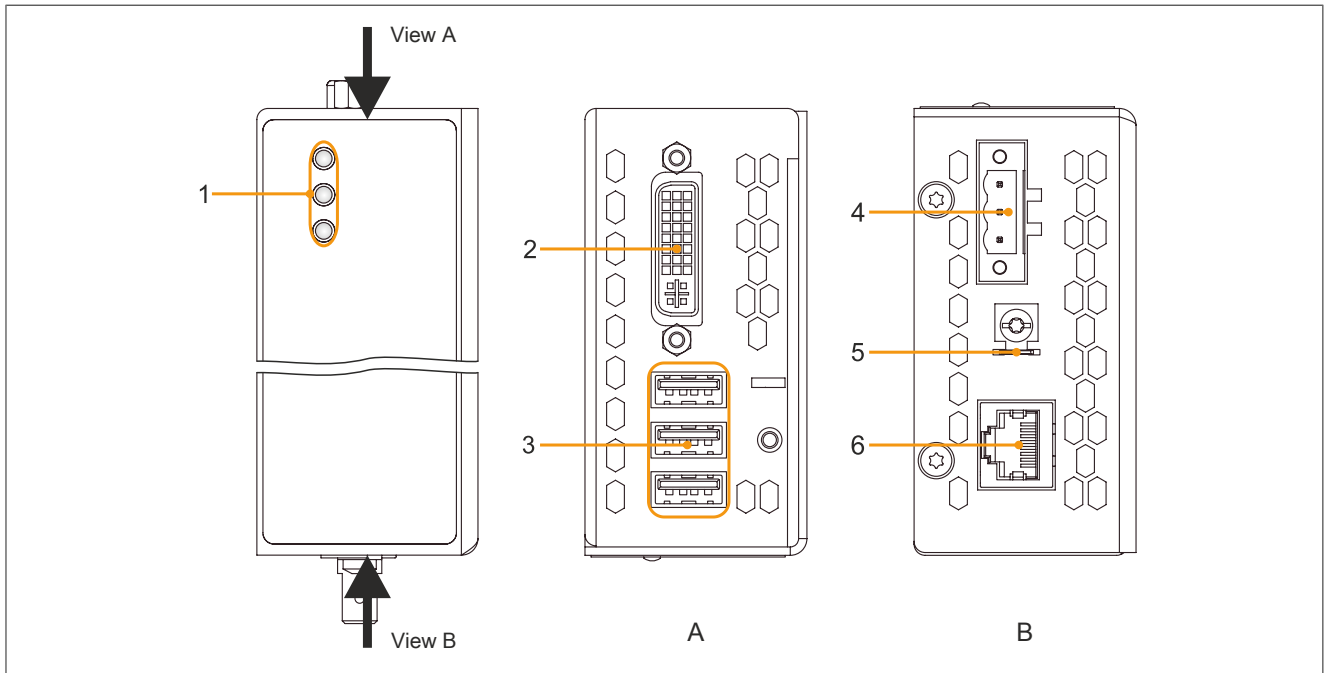

Legend			
1	"LED status indicators" on page 18	4	"+24 VDC power supply" on page 15
2	"DVI Out interface" on page 17	5	"Grounding" on page 16
3	"USB interfaces" on page 18	6	"SDL4 In interface" on page 16

3.5.2.1.1 +24 VDC power supply

Danger!

The device is only permitted to be supplied with a SELV/PELV power supply or with safety extra-low voltage (SELV) per EN 60950.

The necessary 3-pin connector is not included in delivery; for suitable accessories, see "0TB103.9x" on page 36.

The device is protected against overload and reverse polarity by a soldered fuse (10 A, fast-acting). If the fuse is defective (e.g. due to overload), the device must be sent to B&R for repairs. If the polarity is reversed, it is not necessary to replace the fuse.

Pin	Description	Figure
1	+	
2	Functional ground	
3	-	
<ul style="list-style-type: none"> Reverse polarity protection 3-pin Male 		
Electrical properties		
Nominal voltage		24 VDC ±25%, SELV ¹⁾
Nominal current		Max. 0.5 A
Overvoltage category per EN 61131-2		II
Galvanic isolation		Yes

1) EN 60950 requirements must be observed.

3.5.2.1.2 Grounding

Caution!

The functional ground (power supply pin 2 and ground connection) must be connected to the central grounding point (e.g. control cabinet or system) via the shortest possible path with the lowest possible resistance and with the largest possible wire cross section. This type of grounding is mandatory for proper functionality.

For example, a copper strip must be attached to the ground connection at a central grounding point of the control cabinet or system in which the device is installed. The wire cross section should be as large as possible (at least 2.5 mm²).

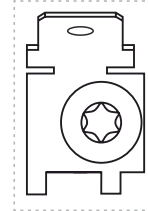

3.5.2.1.3 SDL4 In interface

The SDL4 In interface is a female RJ45 connector and operated with SDL4 transmission technology.

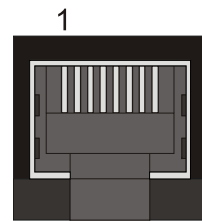

Information:

Hot plugging output devices on the interface for service purposes is supported by the hardware and graphic drivers of approved operating systems.

A maximum of 500 mating cycles are specified for this interface.

3.5.2.1.4 DVI Out interface

The DVI interface is a female DVI-I connector with a maximum resolution of 1920 x 1200 pixels and uses DVI-D transmission technology.

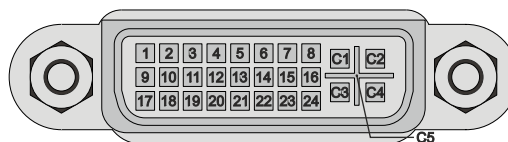

Information:

Hot plugging output devices on the interface for service purposes is supported by the hardware and graphic drivers of approved operating systems.

A maximum of 100 mating cycles are specified for this interface.

Pinout

Pin	Pinout	Description	Pin	Pinout	Description
1	TMDS data 2-	DVI lane 2 (negative)	16	HPD	Hot plug detection
2	TMDS data 2+	DVI lane 2 (positive)	17	TMDS data 0-	DVI lane 0 (negative)
3	TMDS data 2/4 SHIELD	Shield for data pairs 2 and 4	18	TMDS data 0+	DVI lane 0 (positive)
4	Not connected	Not connected	19	TMDS data 0/XUSB1 SHIELD	Shield of data pair 0 and USB1
5	Not connected	Not connected	20	Not connected	Not connected
6	DDC clock	DDC-based control signal (clock)	21	Not connected	Not connected
7	DDC data	DDC-based control signal (data)	22	TMDS clock shield	Shield of clock pair
8	Not connected	Not connected	23	TMDS clock+	DVI clock (positive)
9	TMDS data 1-	DVI lane 1 (negative)	24	TMDS clock -	DVI clock (negative)
10	TMDS data 1+	DVI lane 1 (positive)	C1	Not connected	Not connected
11	TMDS data 1/XUSB0 SHIELD	Shield of data pair 1 and USB0	C2	Not connected	Not connected
12	Not connected	Not connected	C3	Not connected	Not connected
13	Not connected	Not connected	C4	Not connected	Not connected
14	+5 V power ¹⁾	+5 V power supply	C5	Not connected	Not connected
15	Ground (return for +5 V, HSync and VSync)	Ground	-		-

1) Protected internally by a multifuse.

3.5.2.1.4.1 Cable lengths and resolutions for DVI transfer

The following table shows the relationship between segment length and maximum resolution depending on the DVI cable:

DVI cable Segment length [m]	Resolution						
	VGA 640 x 480	SVGA 800 x 600	XGA 1024 x 768	HD 1366 x 768	SXGA 1280 x 1024	UXGA 1600 x 1200	FHD 1920 x 1080
1.8	5CADVI.0018-00	5CADVI.0018-00	5CADVI.0018-00	5CADVI.0018-00	5CADVI.0018-00	5CADVI.0018-00	5CADVI.0018-00
5	5CADVI.0050-00	5CADVI.0050-00	5CADVI.0050-00	5CADVI.0050-00	5CADVI.0050-00	5CADVI.0050-00	5CADVI.0050-00

System overview

3.5.2.1.5 LED status indicators

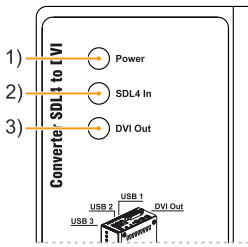
Position	LED	Color	Status	Explanation
	Power 1)	Green	On	Device ready for operation
	SDL4 In 2)	Yellow	On	Active SDL4 connection.
	DVI Out 3)	Yellow	Blinking (approx. 2.5 Hz)	Active DVI connection.
			Off	No DVI connection.

3.5.2.1.6 USB interfaces

Warning!

USB peripheral devices can be connected to the USB interfaces. Due to the variety of USB devices available on the market, B&R cannot guarantee their functionality. The functionality of USB devices available from B&R is guaranteed.

USB1-3				
Standard	USB 2.0			
Variant	Type A, female			
Quantity	3			
Transfer rate	Low speed (1.5 Mbit/s)			
	Full speed (12 Mbit/s)			
	High speed (480 Mbit/s)			
Current-carrying capacity ¹⁾	Max. 0.5 A per USB			
Max. ambient temperature (complete system)	Rev. B0	Rev. C0	Rev. D0	
At 3.25 W USB total power	40°C	50°C	55°C	
At 7.50 W USB total power	35°C	40°C	50°C	
Cable length	Max. 5 m (without hub)			

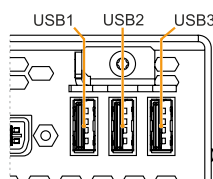

1) The USB interfaces are protected by a maintenance-free "USB current-limiting switch" (max. 0.5 A).

3.6 Overview

Model number	Short description	Page
	Accessories	
0TB103.9	Connector 24 VDC - 3-pin female - Screw clamp terminal block 3.31 mm ²	36
0TB103.91	Connector 24 VDC - 3-pin female - Cage clamp terminal block 3.31 mm ²	36
5ACCRHMI.0012-000	REP strain relief USB - For SDL4/DVI Converter	43
	Converter	
5COSD4.1002-00	SDL4/DVI Converter	12
	DVI cables	
5CADVI.0018-00	DVI-D cable - 1.8 m	40
5CADVI.0050-00	DVI-D cable - 5 m	40
	SDL3/SDL4/PoE cables	
5CASD3.0030-00	SDL3/SDL4/FT50 cable - 3 m - FT50 including Power over Ethernet	37
5CASD3.0050-00	SDL3/SDL4/FT50 cable - 5 m - FT50 including Power over Ethernet	37
5CASD3.0100-00	SDL3/SDL4/FT50 cable - 10 m - FT50 including Power over Ethernet	37
5CASD3.0150-00	SDL3/SDL4/FT50 cable - 15 m - FT50 including Power over Ethernet	37
5CASD3.0200-00	SDL3/SDL4/FT50 cable - 20 m - FT50 including Power over Ethernet	37
5CASD3.0300-00	SDL3/SDL4/FT50 cable - 30 m - FT50 including Power over Ethernet	37
5CASD3.0500-00	SDL3/SDL4/FT50 cable - 50 m - FT50 including Power over Ethernet	37
5CASD3.1000-00	SDL3/SDL4/FT50 cable - 100 m - FT50 including Power over Ethernet	37

4 Dimensioning

4.1 Spacing for air circulation

To ensure sufficient air circulation, a specified clearance must be provided above, below, to the side and behind the device. For the minimum specified clearance, see the following diagrams. This is valid for all variants.

Information:

The following figure and table exclusively show the thermal view of the complete system. If additional space is required for operating or servicing the device or using accessories (e.g. cable strain relief clips), this must be taken into account during installation.

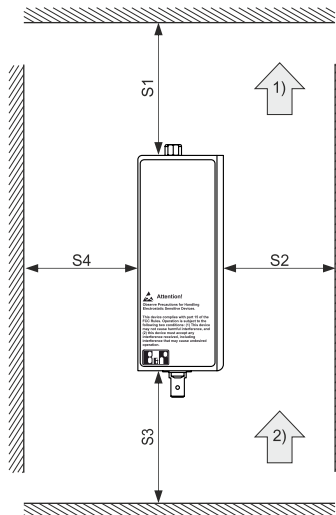

Legend			
1)	Air outlet	2)	Air inlet
Spacing			
Description	Dimension	Description	Dimension
S1	≥ 100	S2	≥ 50
S3	≥ 100	S4	≥ 50

Caution!

The specified spacing for air circulation is based on worst-case operation at the maximum specified ambient temperature. The maximum specified ambient temperature is not permitted to be exceeded!

5 Installation and wiring

5.1 Basic information

A damaged device has unpredictable properties and states. The unintentional installation or startup of a damaged device must be prevented. The damaged device must be marked as such and made inaccessible, or it must be returned for repairs immediately.

Unpacking

The following activities must be performed before unpacking the device:

- Check the packaging for visible transport damage.
- If transport damage is noticeable, document this immediately and submit a complaint. If possible, have the damage confirmed by the carrier/delivery service.
- Check the contents of the shipment for completeness and damage.
- If the contents of the packaging are incomplete, damaged or do not correspond to your order, you must immediately inform your responsible sales office or B&R Headquarters.
- Keep the original packaging for further transport.

Power supply

The following information is generally applicable and should be observed before performing any work on the device:

- The entire power supply must be disconnected before removing any covers or components from the device and installing or removing any accessories, hardware or cables.
- Remove the power cable from the device and from the power supply.
- All covers and components, accessories, hardware and cables must be installed or secured before the device is connected to the power supply and switched on.

Installation

Information:

Optional sets are available that contain all necessary tools for installation. For more information about tool sets, see section "General accessories" on page 35.

Before installation

Caution!

If the load-bearing capacity of the mounting surface is insufficient, or if the fastening material is inadequate or incorrect, the device may fall and become damaged.

The following activities and limitations must be observed before installing the device.

- Allow sufficient space for installation, operation and maintenance of the device.
- The device must be installed on a flat, clean and burr-free surface.
- The wall or control cabinet plate must be able to support four times the total weight of the device. If necessary, bracing must be attached to reinforce the mounting surface.
- To avoid overheating, the device is not permitted to be placed near other heat sources.

Information about the device's environment

- Observe the notes and regulations regarding the power supply and functional ground.
- Observe the specified bend radius when connecting cables.
- Any ventilation holes are not permitted to be covered.
- This device is only approved for use in closed rooms and not permitted to be exposed to direct sunlight.
- The climatic and ambient conditions must be taken into account, see the technical data of the converter used.

General installation instructions

- When installed in a closed housing, there must be sufficient volume for air circulation, see "[Spacing for air circulation](#)" on page 20.
- When connecting installed or connected peripherals, follow the instructions in the peripheral device's documentation.

Transport and storage

When transporting at low temperatures or in the event of large temperature fluctuations, the collection of moisture in or on the device is not permitted. Moisture can cause short circuits in electrical circuits and damage the device.

If a device is transported or stored without packaging, all environmental influences such as shocks, vibrations, pressure and moisture have an unprotected effect on the device. Damaged packaging indicates that the device has been severely affected by environmental influences and may have been damaged.

This can result in malfunctions of the device, machine or system.

5.2 Installing the SDL4/DVI Converter

The frame on the back of the device allows the system to be installed on a top-hat rail (TS35) that corresponds to the EN 50022 standard.

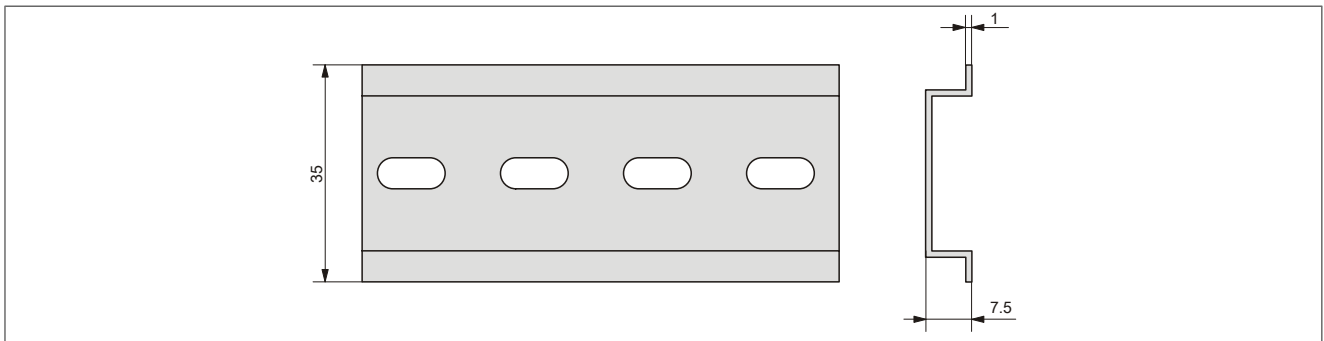
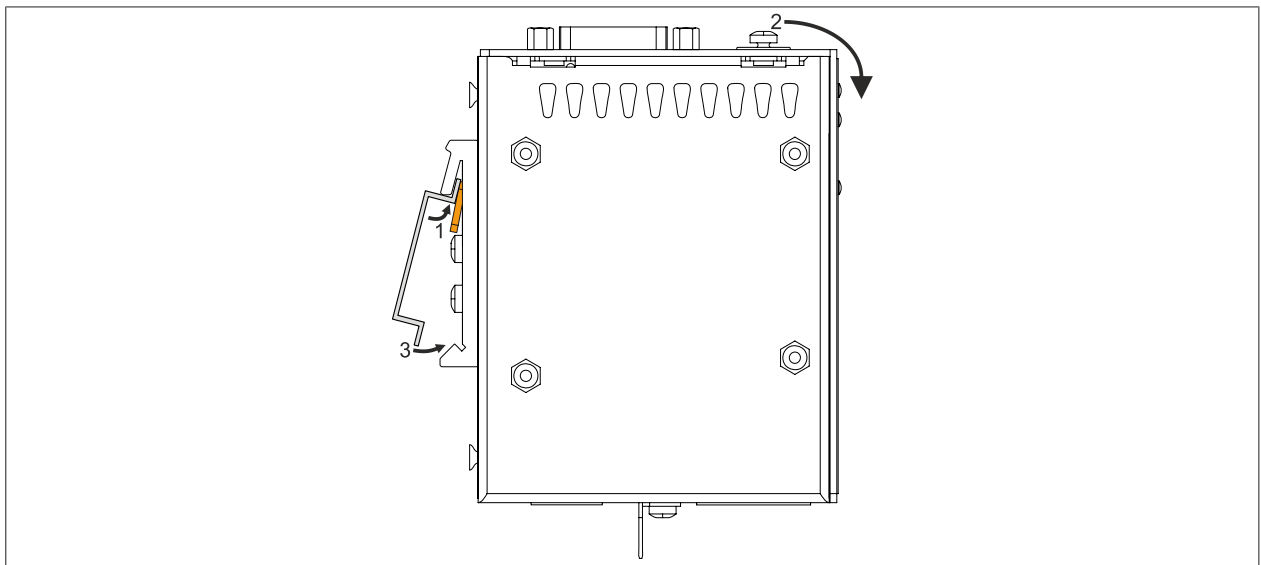

Figure 1: Top-hat rail

5.2.1 Procedure

1. Attach the SDL4/DVI Converter in the desired position to the top-hat rail (1) and press down (2) on the device to engage the locking mechanism (3).



5.3 Installing the cable strain relief clip

1. The cable strain relief clip must be positioned on the SDL4/DVI Converter according to the following figure and secured with the supplied locating screws (M3, max. tightening torque 0.5 Nm).
The length overhang is not permitted to be removed, and the cable strain relief clip is not permitted to be installed elsewhere on the device.

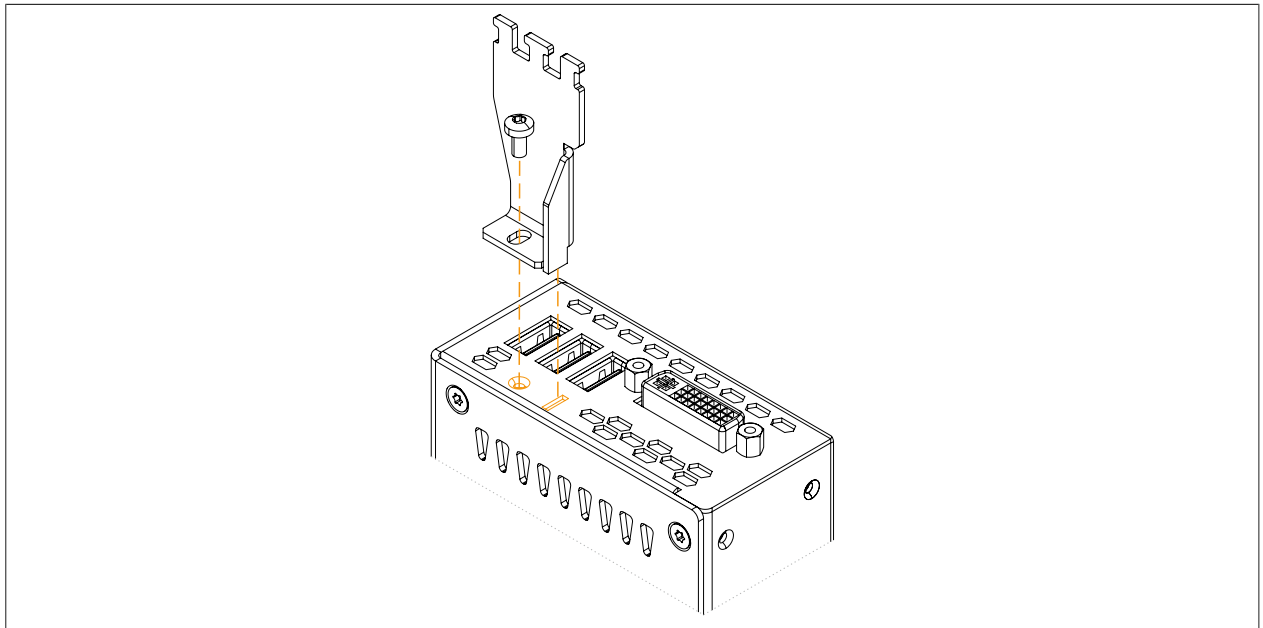

2. The connectors of the connected USB cables must be secured to the cable strain relief clip using the supplied cable ties.



Figure 2: Securing USB cables

5.4 Connecting to the power grid

Danger!

- The entire power supply must be disconnected and electrostatic discharge must take place on the housing or ground connection before removing any covers or components from the device and installing or removing any accessories, hardware or cables.
- Remove the power cable from the device and from the power supply.
- All covers and components, accessories, hardware and cables must be installed or secured before the device is connected to the power supply and switched on.

5.4.1 Installing the DC power cable

Danger!

The entire power supply to the B&R industrial PC or B&R Automation Panel must be interrupted. Before connecting the DC power cable, it must be checked whether it has been disconnected from the voltage source (e.g. power supply).

5.4.1.1 Wiring

Install the DC power cable on the terminal block (power supply connector) as shown in the figure below. Conductors with a cross section of 0.75 mm² to 1.5 mm² and wire end sleeve must be used.

Caution!

The pinout of the power supply interface must be observed!

Installing screw clamp terminal block 0TB103.9

Secure the conductors with wire end sleeves in the terminal contacts ② as shown in the figure below and tighten the screw clamp terminals ① with a screwdriver (max. tightening torque 0.4 Nm).

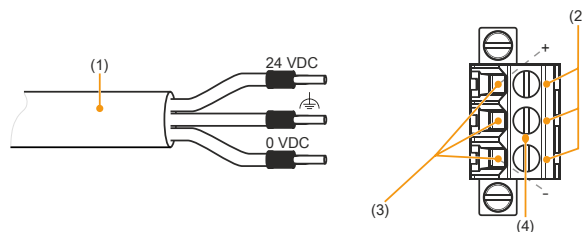

Installing cage clamp terminal block 0TB103.91

Insert a screwdriver into the cage clamp terminals ① and secure the conductors with wire end sleeves in the terminal contacts ② as shown in the figure below. Close the terminal contact by removing the screwdriver.

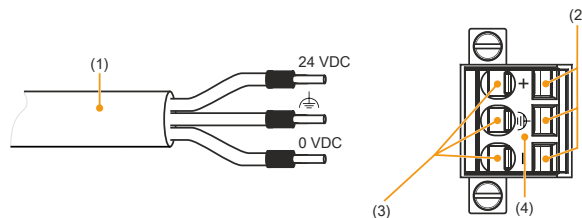

5.4.2 Connecting the power supply to a B&R device

Danger!

The entire power supply to the B&R device must be interrupted. Before connecting the power cable, it must be checked whether it has been disconnected from the voltage source (e.g. power supply).

Installation and wiring

1. Carry out electrostatic discharge on the housing or at the ground connection.
2. Connect the power supply connector to the B&R device and tighten the mounting screws (max. tightening torque 0.5 Nm).

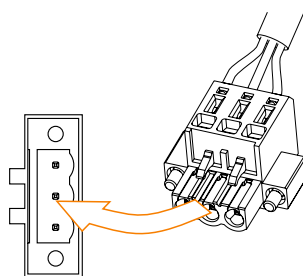

5.4.3 Grounding concept

Functional ground is a current path of low impedance between circuits and ground. It is used to improve immunity to interference, for example, and not as a protective measure. It serves only to divert interference, not to protect against contact with persons.

The device is equipped with 2 functional ground connections:

- Functional ground connection of the power supply
- Ground connection

The following points must be observed to ensure that electrical interference is safely diverted:

- Connect the device to the central grounding point (e.g. the control cabinet or the system) using the shortest possible low-resistance path.
- Cable design with at least 2.5 mm² per connection. If a cable with wire end sleeve is used at terminal block 0TB103.9 or 0TB103.91, a cable with a maximum of 1.5 mm² per connection is possible.
- Observe the shielding concept of the conductors. All data cables connected to the device must be shielded.

The functional ground on the B&R device is marked with the following symbol: 

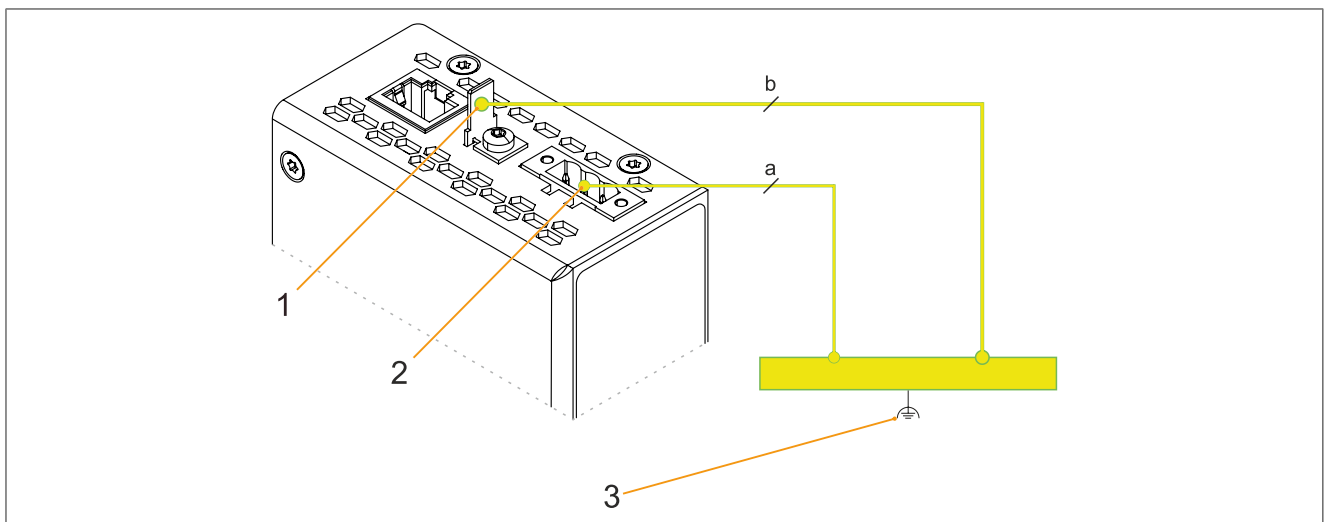



Figure 3: On the 5COSD4.1002-00, the grounding and power supply connections are located on the underside of the device.

Legend					
1	Ground connection 	2	Power supply connection +24 VDC pin 2	3	Central grounding point
a	At least 1.5 mm ²	b	At least 2.5 mm ²		-

5.5 Connecting cables

When connecting or installing cables, the bend radius specification must be observed. For this specification, see the technical data of the respective cable.

The maximum tightening torque of the locating screws is 0.5 Nm.

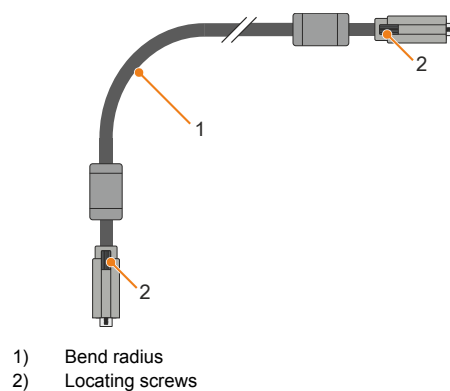

5.6 Removing the SDL4/DVI Converter

5.6.1 Procedure

1. Pull the SDL4/DVI Converter downwards (1) and slightly in the opposite direction away from the top-hat rail (2). This releases the locking mechanism for the top-hat rail installation.

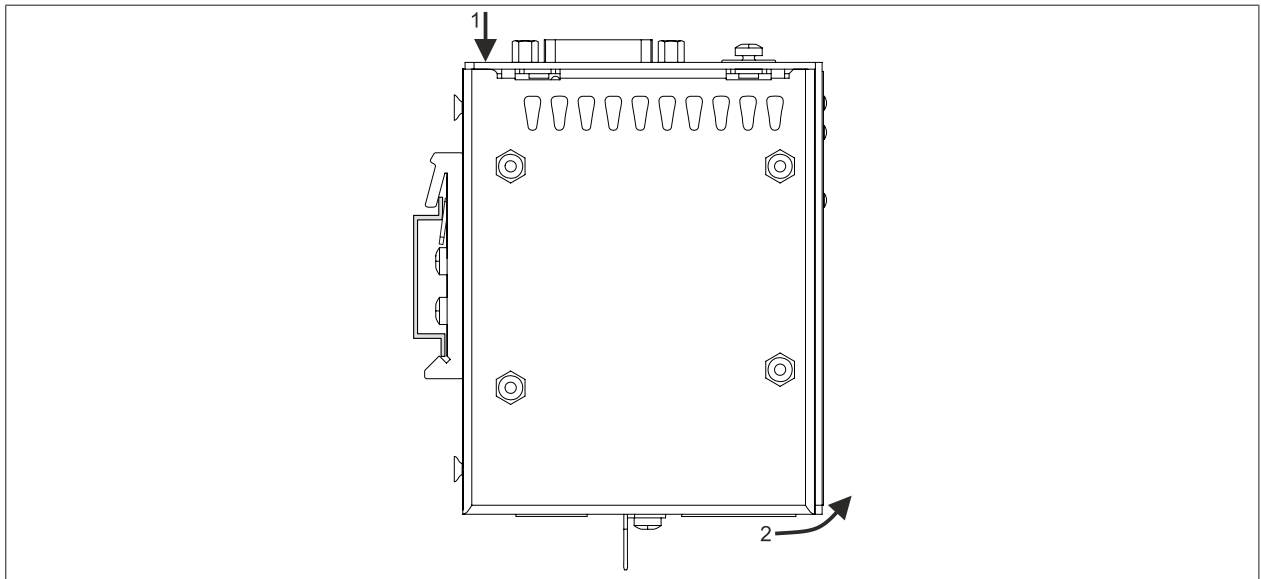

6 Commissioning

6.1 Basic information

Before the device is started up, it must be gradually adapted to room temperature!

6.2 Switching on the device for the first time

6.2.1 General information before switching on the device

Checklist

Before the device is started up for the first time, the following points must be checked:

- Have the installation instructions been observed as described in "[Installation and wiring](#)" on page 21?
- Have the permissible ambient conditions and environmental conditions for the device been taken into account?
- Is the power supply connected correctly and have the values been checked?
- Is the ground cable correctly connected to the ground connection?
- Before installing additional hardware, the device must have been started up.

Caution!

Before the device is started up, it must be gradually adapted to room temperature! Exposure to direct heat radiation is not permitted.

When transporting at low temperatures or in the event of large temperature fluctuations, the collection of moisture in or on the device is not permitted.

Moisture can cause short circuits in electrical circuits and damage the device.

Requirements

The following criteria must be met before switching on the device for the first time:

- The functional ground connections are as short as possible and connected to the central grounding point using the largest possible wire cross section.
- All connection cables are connected correctly.
- An Automation PC or Panel PC and monitor or panel are connected.

6.2.2 Switching on the SDL4/DVI Converter

Procedure

1. Connect the power supply and switch it on.
2. The device is operating.

7 Software

7.1 Updates

No updates are required for the SDL4/DVI Converter.

8 Maintenance

The following chapter describes the maintenance work that can be carried out by a qualified and trained end user.

Information:

Only components approved by B&R are permitted to be used for maintenance work.

8.1 Repairs/Complaints and replacement parts

Danger!

Unauthorized opening or repair of a device may result in personal injury and/or serious damage to property. Repairs are therefore only permitted to be carried out by authorized qualified personnel at the manufacturer's premises.

To process a repair/complaint, a repair order or complaint must be created via the B&R Material Return Portal on the B&R website (www.br-automation.com).

9 International and national certifications

9.1 Directives and declarations

9.1.1 CE marking



All directives applicable to the respective product and their harmonized EN standards are met.

9.1.2 EMC Directive

The products meet the requirements of EU directive "Electromagnetic compatibility 2014/30/EU" and are designed for industrial applications:

EN 61131-2:2007	Programmable controllers - Part 2: Equipment requirements and tests
EN 61000-6-2:2005	Electromagnetic compatibility (EMC) - Part 6-2: Generic standards - Immunity for industrial environments
EN 61000-6-4:2007	Electromagnetic compatibility (EMC) - Part 6-4: Generic standards - Emission standard for industrial environments

Information:

The declarations of conformity are available on the B&R website under [Downloads - Certificates - Declarations of conformity](#).

9.2 Certifications

Danger!

A complete system can only receive certification if all individual components installed and connected in it have the corresponding certifications. If an individual component is used that does not have the corresponding certification, the complete system will also not be certified.

B&R products and services comply with applicable standards. These are international standards from organizations such as ISO, IEC and CENELEC, as well as national standards from organizations such as UL, CSA, FCC, VDE, ÖVE, etc. We pay special attention to the reliability of our products in the industrial sector.

Information:

The certifications valid for the respective product are available on the website and in the user's manual under the technical data in section "Certifications" or in the associated certificates.

9.2.1 UL certification



Ind. Cont. Eq.
E115267

Products with this mark are tested by Underwriters Laboratories and listed as "industrial control equipment". The mark is valid for the USA and Canada and facilitates the certification of your machines and systems in this economic area.

Underwriters Laboratories (UL) per standards UL 61010-1 and UL 61010-2-201 Canadian (CSA) standard per C22.2 No. 61010-1-12 and CSA C22.2 No. 61010-2-201:14

The UL certificates are available on the B&R website under [Downloads - Certificates - UL](#).

When using industrial control equipment per UL 61010-1 / UL 61010-2-201, make sure that the device is classified as "open type". The prerequisite for certification or operation per UL 61010-1 / UL 61010-2-201 is therefore the installation of the device in an appropriate protective housing.

9.2.2 EAC



Products with this mark are tested by an accredited test laboratory and permitted to be imported into the Eurasian Customs Union (based on EU conformity).

10 Accessories

The following accessories have undergone functional testing by B&R in connection with the device used and can be operated with this device. Possible limitations regarding operation with individual components other than the complete system must be taken into account, however. All individual specifications of the components must be observed when operating the complete system.

All components listed in this manual have undergone intensive system and compatibility testing and been approved accordingly. B&R cannot assume any functional warranty for accessories that have not been approved.

10.1 General accessories

The following accessories can be ordered for the Automation PC, Panel PC and Converter:

- Grounding clip
- Cable strain relief clip for USB (see ["Cable strain relief clip" on page 43](#))

10.1.1 Accessories - Order data

Material number	Description
5ACCRHMI.0000-000	REP HMI grounding clip
5ACCRHMI.0012-000	REP strain relief USB - For SDL4/DVI Converter

Accessories

10.2 0TB103.9x

10.2.1 General information

1-row 3-pin terminal block 0TB103 is used for the power supply.

10.2.2 Order data

Model number	Short description	Figure
	Accessories	
0TB103.9	Connector 24 VDC - 3-pin female - Screw clamp terminal block 3.31 mm ²	
0TB103.91	Connector 24 VDC - 3-pin female - Cage clamp terminal block 3.31 mm ²	

Table 3: 0TB103.9, 0TB103.91 - Order data

10.2.3 Technical data

Information:

The following specified characteristic data, features and limit values are only valid for this accessory and may differ from those of the complete system. The data specified for the complete system applies to the complete system in which this accessory is installed, for example.

Model number	0TB103.9	0TB103.91
General information		
Certifications		
CE	Yes	
EAC	Yes	
UL	cULus E115267 Industrial control equipment	
HazLoc	cULus HazLoc E180196 Industrial control equipment for hazardous locations Class I, Division 2, Groups ABCD, T4 ¹⁾	
DNV GL	Temperature: B (0 - 55°C) Humidity: B (up to 100%) Vibration: A (0.7 g) EMC: B (bridge and open deck) ²⁾	
Terminal block		
Note	Protected against vibration by the screw flange Nominal data per UL	
Number of pins	3 (female)	
Type of terminal block	Screw clamp terminal block variant	Cage clamp terminal block variant ³⁾
Cable type	Only copper wires (no aluminum wires!)	
Pitch	5.08 mm	
Connection cross section		
AWG wire	26 to 14 AWG	26 to 12 AWG
Wire end sleeves with plastic covering	0.20 to 1.50 mm ²	
Solid wires	0.20 to 2.50 mm ²	
Fine-stranded wires	0.20 to 1.50 mm ²	0.20 to 2.50 mm ²
With wire end sleeves	0.20 to 1.50 mm ²	
Tightening torque	0.4 Nm	-
Electrical properties		
Nominal voltage	300 V	
Nominal current ⁴⁾	10 A / contact	
Contact resistance	≤5 mΩ	
Operating conditions		
Pollution degree per EN 61131-2	Pollution degree 2	

Table 4: 0TB103.9, 0TB103.91 - Technical data

- 1) Yes, but applies only if all components installed in the complete system have this certification and the complete system bears the corresponding mark.
- 2) Yes, but applies only if all components installed in the complete system have this certification and are listed on the associated DNV GL certificate for the product family.
- 3) The cage clamp terminal block cannot be used side by side.
- 4) The respective limit data of the I/O modules must be taken into account!

10.3 Cables

10.3.1 SDL3/SDL4 cables

10.3.1.1 5CASD3.xxxx-00

10.3.1.1.1 General information

5CASD3.xxxx-00 SDL3/SDL4 cables are designed to transfer SDL3/SDL4 data and enable easy cable installation. Due to the RJ45 connector, the cable is also suitable for narrow feed-throughs, e.g. in swing arm shafts.

Caution!

The cable is only permitted to be connected/disconnected when the power is switched off.

10.3.1.1.2 Order data

Model number	Short description	Figure
	SDL3/SDL4/PoE cables	
5CASD3.0030-00	SDL3/SDL4/FT50 cable - 3 m - FT50 including Power over Ethernet	
5CASD3.0050-00	SDL3/SDL4/FT50 cable - 5 m - FT50 including Power over Ethernet	
5CASD3.0100-00	SDL3/SDL4/FT50 cable - 10 m - FT50 including Power over Ethernet	
5CASD3.0150-00	SDL3/SDL4/FT50 cable - 15 m - FT50 including Power over Ethernet	
5CASD3.0200-00	SDL3/SDL4/FT50 cable - 20 m - FT50 including Power over Ethernet	
5CASD3.0300-00	SDL3/SDL4/FT50 cable - 30 m - FT50 including Power over Ethernet	
5CASD3.0500-00	SDL3/SDL4/FT50 cable - 50 m - FT50 including Power over Ethernet	
5CASD3.1000-00	SDL3/SDL4/FT50 cable - 100 m - FT50 including Power over Ethernet	

Table 5: 5CASD3.0030-00, 5CASD3.0050-00, 5CASD3.0100-00, 5CASD3.0150-00, 5CASD3.0200-00, 5CASD3.0300-00, 5CASD3.0500-00, 5CASD3.1000-00 - Order data

10.3.1.1.3 Technical data

Information:

The following specified characteristic data, features and limit values are only valid for this accessory and may differ from those of the complete system. The data specified for the complete system applies to the complete system in which this accessory is installed, for example.

Model number	5CASD3.0030-00	5CASD3.0050-00	5CASD3.0100-00	5CASD3.0150-00	5CASD3.0200-00	5CASD3.0300-00	5CASD3.0500-00	5CASD3.1000-00
General information								
Certifications								
CE	Yes							
EAC	Yes							
UL	cULus E115267 Industrial control equipment							
HazLoc	cULus HazLoc E180196 Industrial control equipment for hazardous locations Class I, Division 2, Groups ABCD, T4 ¹⁾							
Cable construction								
Wire cross section	4x 2x 26/7 AWG				4x 2x 23/1 AWG			
Properties	Flame-retardant, halogen-free, lead-free							
Outer jacket								
Material	Polyurethane (PUR)							
Color	Yellow, RAL 1021							
Labeling	HARTING INDUSTRIAL CABLE S/FTP CAT 6A PUR 4x2xAWG26/7					HARTING INDUSTRIAL INSTALLATION CABLE S/FTP CAT 7 PUR 4x2xAWG23/1		

Table 6: 5CASD3.0030-00, 5CASD3.0050-00, 5CASD3.0100-00, 5CASD3.0150-00, 5CASD3.0200-00, 5CASD3.0300-00, 5CASD3.0500-00, 5CASD3.1000-00 - Technical data

Accessories

Model number	5CASD3.0030-00	5CASD3.0050-00	5CASD3.0100-00	5CASD3.0150-00	5CASD3.0200-00	5CASD3.0300-00	5CASD3.0500-00	5CASD3.1000-00
Wires								
Wire insulation	Polyethylene (PE)							
Wire colors	Green/White-green, orange/white-orange, blue/white-blue, brown/white-brown							
Shield	Aluminum foil and braided wire shield composed of tinned copper wires							
Type	Bare copper strand, 4x 2x 26/7 AWG				Bare copper strand, 4x 2x 23/1 AWG			
Connector								
Type	2x RJ45, male							
Mating cycles	Min. 750							
Contacts	8							
Electrical properties ²⁾								
Operating voltage	≤100 V				≤125 V			
Conductor resistance	≤290 Ω/km				≤75 Ω/km			
Wave impedance	100 ±5 Ω (at 100 MHz)							
Transfer properties	Category 6A / Class EA up to 500 MHz per ISO/IEC 11801 (EN 50173-1), ISO/IEC 24702 (EN 50173-3)				Category 7 / Class F up to 600 MHz per ISO/IEC 11801 (EN 50173-1), ISO/IEC 24702 (EN 50173-3)			
Insulation resistance	≥500 MΩ/km				≥5 GΩ/km			
Operating conditions								
Pollution degree per EN 61131-2	Pollution degree 2							
Flame-retardant	IEC 60332-1-2							
Oil and hydrolysis resistance	EN 60811-2-1 (90°C / 7x24 h)							
Degree of protection per EN 60529								
Cables	IP20							
RJ45 connector	IP20, only when properly connected							
Ambient conditions								
Temperature								
Storage	-40 to 70°C							
Fixed installation	-40 to 70°C							
Flexible installation	-40 to 70°C				-10 to 50°C			
Mechanical properties								
Dimensions								
Length	3 m	5 m	10 m	15 m	20 m	30 m	50 m	100 m
Diameter	6.7 mm				8.3 mm			
Bend radius								
Fixed installation	≥5x diameter				≥4x diameter			
Flexible installation	≥10x diameter				≥8x diameter			
Weight								
	250 g	500 g	700 g	950 g	2150 g	3500 g	6950 g	
Tension								
In operation	≤70 N				≤110 N			
During installation	≤70 N				≤110 N			

Table 6: 5CASD3.0030-00, 5CASD3.0050-00, 5CASD3.0100-00, 5CASD3.0150-00, 5CASD3.0200-00, 5CASD3.0300-00, 5CASD3.0500-00, 5CASD3.1000-00 - Technical data

- 1) Yes, but applies only if all components installed in the complete system have this certification and the complete system bears the corresponding mark.
- 2) At 20°C ambient temperature.

10.3.1.1.4 Bend radius specification

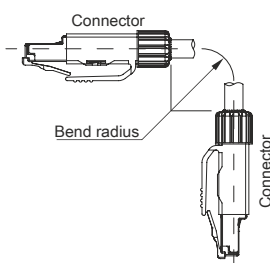

10.3.1.1.5 Dimensions

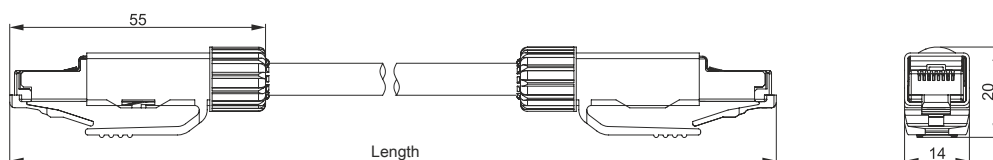

10.3.1.1.6 Cable pinout

If you wish to assemble a suitable cable yourself, the cable must be wired according to this pinout.

Information:

Functionality is only guaranteed for the cables available from B&R.

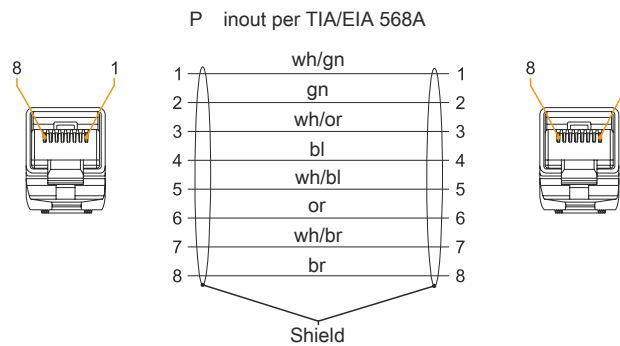

10.3.1.1.7 Wiring

The following information and figure apply if a field-assembled cable is used and connected to an RJ45 network connector (e.g. patch panel) instead of directly to a B&R device.

The wiring must comply with category 6A (Cat 6A) or 7 (Cat 7) requirements. The maximum total length of 100 m is not permitted to be exceeded.

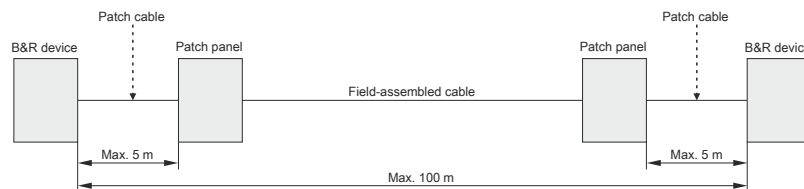

10.3.2 DVI cables

10.3.2.1 5CADVI.0xxx-00

10.3.2.1.1 General information

5CADVI.0xxx-00 DVI cables are designed for use in fixed installations.

Caution!

The cable is only permitted to be connected/disconnected when the power is switched off.

10.3.2.1.2 Order data

Model number	Short description	Figure
	DVI cables	
5CADVI.0018-00	DVI-D cable - 1.8 m	
5CADVI.0050-00	DVI-D cable - 5 m	

Table 7: 5CADVI.0018-00, 5CADVI.0050-00 - Order data

10.3.2.1.3 Technical data

Information:

The following specified characteristic data, features and limit values are only valid for this accessory and may differ from those of the complete system. The data specified for the complete system applies to the complete system in which this accessory is installed, for example.

Model number	5CADVI.0018-00	5CADVI.0050-00
General information		
Certifications		
CE	Yes	
UL	cULus E115267 Industrial control equipment	
DNV GL	Temperature: B (0 - 55°C) Humidity: B (up to 100%) Vibration: A (0.7 g) EMC: B (bridge and open deck) ¹⁾	
GOST-R	Yes	
Cable construction		
Wire cross section	28 AWG	
Shield	Individual cable pairs, entire cable	
Cable shield	Tinned copper braiding, optical coverage > 86%	
Outer jacket		
Material	PVC	
Color	Beige	
Labeling	AWM STYLE 20276 80°C 30V VW1 DVI DIGITAL SINGLE LINK DER AN	
Connector		
Type	2x DVI-D (18+1), male	
Mating cycles	100	
Locating screw tightening torque	Max. 0.5 Nm	
Electrical properties		
Conductor resistance	Max. 237 Ω/km	
Insulation resistance	Min. 100 MΩ/km	
Operating conditions		
Pollution degree per EN 61131-2	Pollution degree 2	
Mechanical properties		
Dimensions		
Length	1.8 m ±50 mm	5 m ±80 mm
Diameter	Max. 8.5 mm	
Bend radius	≥5x cable diameter (connector to ferrite bead and ferrite bead to ferrite bead)	
Weight	Approx. 260 g	Approx. 460 g

Table 8: 5CADVI.0018-00, 5CADVI.0050-00 - Technical data

1) Yes, but applies only if all components installed in the complete system have this certification and are listed on the associated DNV GL certificate for the product family.

10.3.2.1.4 Bend radius specification

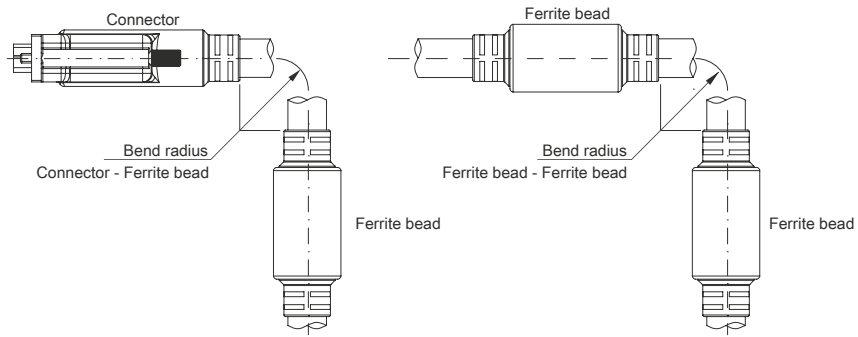

10.3.2.1.5 Dimensions

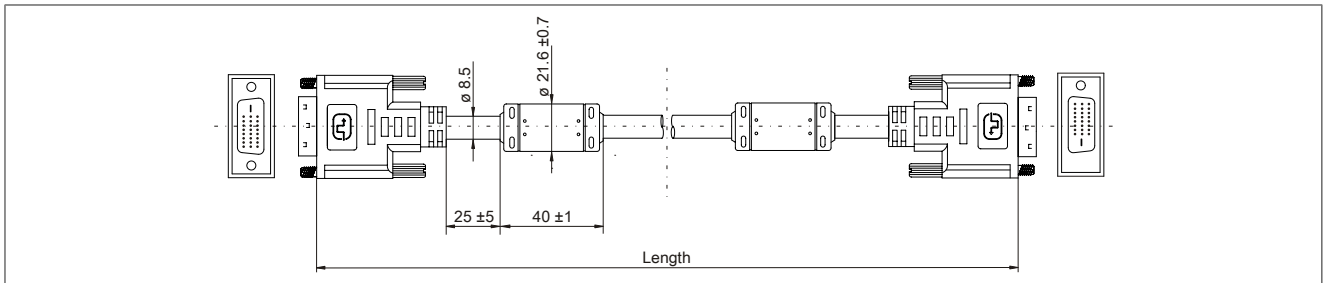

10.3.2.1.6 Cable pinout

If you wish to assemble a suitable cable yourself, the cable must be wired according to this pinout.

Information:

Functionality is only guaranteed for the cables available from B&R.

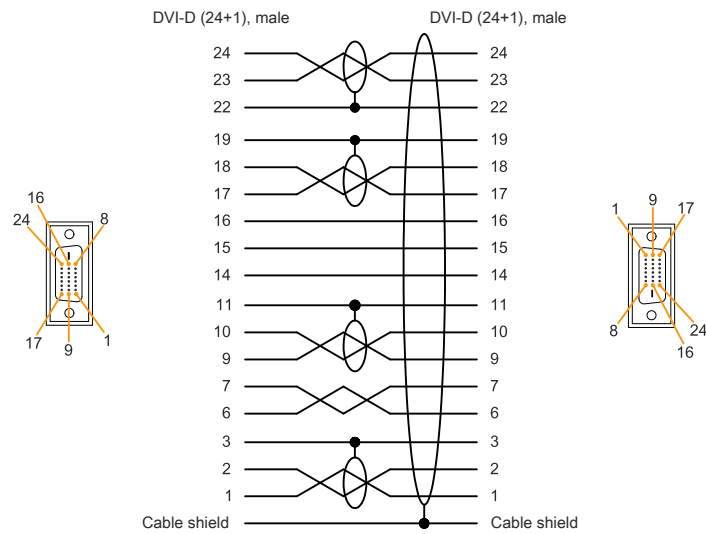

10.4 Cable strain relief clip

10.4.1 5ACCRHMI.0012-000

10.4.1.1 General information

Cable strain relief clip 5ACCRHMI.0012-000 is available for the SDL4/DVI Converter.

The locating screws and cable ties required for installation on the device are included in delivery. For details about installation, see "[Installing the cable strain relief clip](#)" on page 24.

10.4.1.2 Order data

Model number	Short description	Figure
5ACCRHMI.0012-000	Accessories REP strain relief USB - For SDL4/DVI Converter	

Table 9: 5ACCRHMI.0012-000 - Order data

10.4.1.3 Technical data

Model number	5ACCRHMI.0012-000
General information	
Certifications	
CE	Yes
UL	Not relevant
Mechanical properties	
Material	Stainless steel
Dimensions	
Width	25 mm
Length	50 mm (including length overhang)
Depth	10 mm
Weight	Approx. 15 g
Locating screws	
Quantity	1

Table 10: 5ACCRHMI.0012-000 - Technical data

11 Environmentally friendly disposal

All programmable logic controllers, operating and monitoring devices and uninterruptible power supplies from B&R are designed to have as little impact on the environment as possible.

11.1 Separation of materials

To ensure that devices can be recycled in an environmentally friendly manner, it is necessary to separate out the different materials.

Component	Disposal
Programmable logic controllers Operating and monitoring devices Uninterruptible power supplies Batteries and rechargeable batteries Cables	Electronics recycling
Paper/Cardboard packaging	Paper/Cardboard recycling
Plastic packaging material	Plastic recycling

Disposal must be carried out in accordance with applicable legal regulations.

Publishing information

B&R Industrial Automation GmbH

B&R Strasse 1

5142 Eggelsberg

Austria

Telephone: +43 7748 6586-0

Fax: +43 7748 6586-26

office@br-automation.com